

INSTRUCTION SHEET MERCARB TWO-BARREL

50-766-4

GENERAL EXPLODED VIEW

The general design and parts shown will vary to individual units covered on this instruction sheet

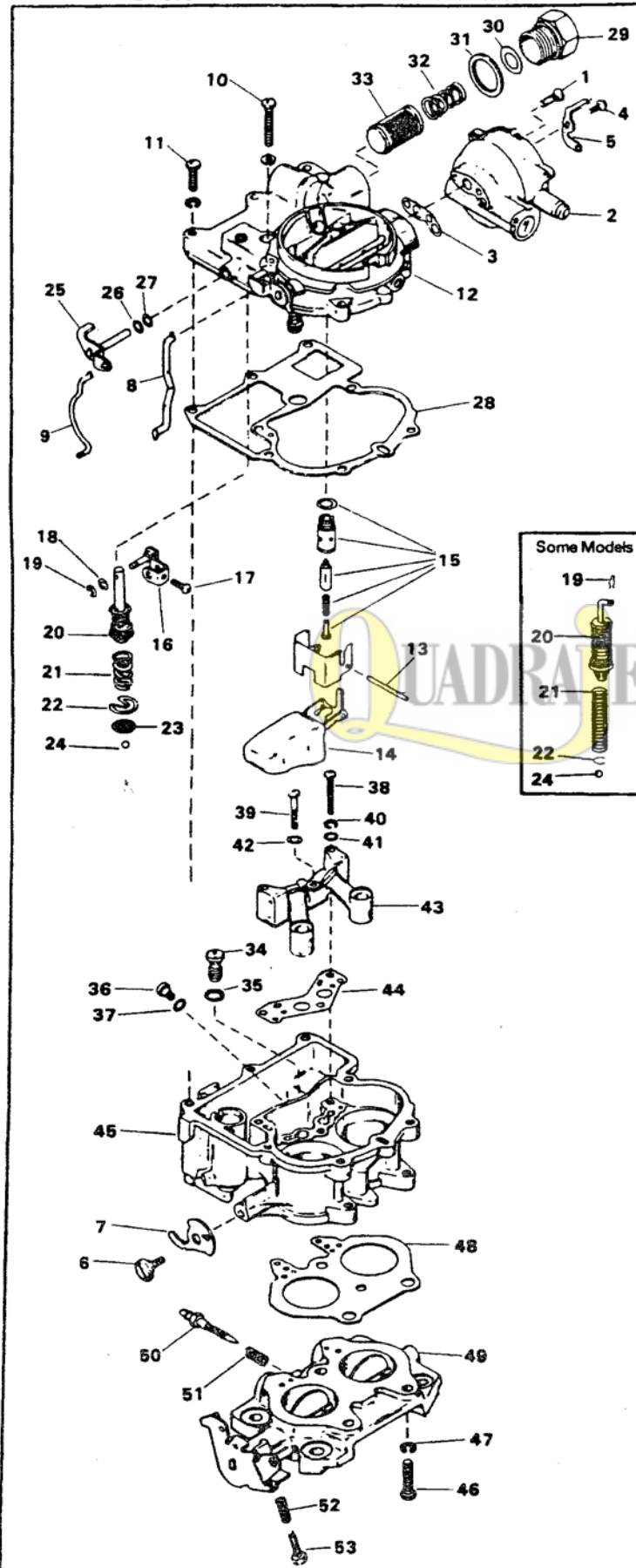

DISASSEMBLY

Use exploded view as guide. The numerical sequence may generally be followed to disassemble unit far enough to permit cleaning and inspection.

NOMENCLATURE

Reference Number	Reference Number
1. Screw, Choke Housing	28. Gasket, Bowl Cover
2. Choke Housing Assembly	29. Fitting, Fuel Inlet
3. Gasket, Choke Housing	30. Gasket, Fuel Inlet
4. Screw, Choke Lever	31. Gasket, Fuel Inlet
5. Lever	32. Spring, Fuel Filter
6. Screw, Fast Idle Cam	33. Filter
7. Fast Idle Cam	34. Power Valve Assembly
8. Choke Rod	35. Gasket, Power Valve
9. Pump Rod	36. Jet
10. Screw, Bowl Cover (Long)	37. Gasket, Jet
11. Screw, Bowl Cover (Short)	38. Screw, Venturi Assembly
12. Bowl Cover Assembly	39. Screw, Venturi Center
13. Pin, Float	40. Lockwasher
14. Float	41. Gasket
15. Needle & Seat Assembly	42. Gasket
16. Pump Shaft & Lever Assembly	43. Venturi Cluster
17. Screw, Pump Shaft Assembly	44. Gasket, Venturi Cluster
18. Washer, Pump Shaft	45. Float Bowl Assembly
19. Retainer, Pump Shaft	46. Screw, Throttle Body
20. Accelerator Pump Assembly	47. Lockwasher
21. Spring, Pump Assembly	48. Gasket, Throttle Body
22. Retainer, Spring	49. Throttle Body
23. Strainer	50. Needle, Idle Mixture Adjusting
24. Check Ball	51. Spring, Idle Mixture Screw
25. Accelerator Pump Lever	52. Screw, Idle Speed Adjusting
26. Washer, Inner	53. Spring, Idle Speed Screw
27. Washer, Outer	

CLEANING

Cleaning must be done with carburetor disassembled. Use a carburetor cleaning solvent to soak parts long enough to soften and remove all foreign material. Make certain the throttle bores are free of all carbon and varnish deposits. Rinse off in suitable solvent. Blow out all passages in castings with compressed air and check carefully to ensure thorough cleaning of obscure areas.

CAUTION: Do not soak float, solenoids, diaphragm units, plastic washers when used or rubber parts in cleaning solvents. Do not sand, wire brush or file on Teflon-coated shafts.

REASSEMBLY

Reassemble in reverse order of disassembly. Note special instructions and follow numerical outline in making adjustments necessary for carburetor being serviced.

SPECIAL INSTRUCTIONS

Idle adjusting needles: Turn each needle in lightly until seated, then back out two turns. (Do not install idle limiter caps at this time.)

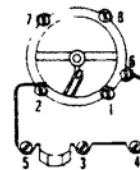

Air Horn Tightening Sequence

The specifications in this chart replace the specifications found in the service manuals. See MerCruiser Service Bulletin 97-8.

CYL	MODEL/ENGINE	CARBURETOR NUMBER	FLOAT LEVEL	FLOAT DROP	PUMP ROD	CHOKE SETTING	CHOKE UNLOADER	FLOAT WEIGHT
4	MCM 120/140	1389-8490A 2	3/8" (10mm) Solid-Needle * 9/16" (14mm) Spring-Needle	1-3/32" (27 mm)	1-5/32" (29mm)	1 Lean clockwise	5/64" (2mm)	9 Grams
	MCM 120/140	1389-9350A 2	3/8" (10mm) Solid-Needle * 9/16" (14mm) Spring-Needle	1-3/32" (27 mm)	1-5/32" (29mm)	1 Lean clockwise	5/64" (2mm)	9 Grams
	MCM 120/140	1389-9562A 1	3/8" (10mm) Solid-Needle * 9/16" (14mm) Spring-Needle	1-3/32" (27 mm)	1-5/32" (29mm)	1 Lean clockwise	5/64" (2mm)	9 Grams
	MCM 2.5L/3.0L	3310-806077A 2	3/8" (10mm) Solid-Needle * 9/16" (14mm) Spring-Needle	1-3/32" (27 mm)	1-5/32" (29mm)	1 Lean clockwise	5/64" (2mm)	9 Grams
	MCM 2.5/3.0L	3310-860070A 2	3/8" (10mm) Solid-Needle * 9/16" (14mm) Spring-Needle	1-3/32" (27 mm)	1-5/32" (29mm)	1 Lean clockwise	5/64" (2mm)	9 Grams
	MCM 3.0L	1389-815396A 2	3/8" (10mm) Solid-Needle * 9/16" (14mm) Spring-Needle	1-3/32" (27 mm)	1-5/32" (29mm)	1 Lean clockwise	5/64" (2mm)	9 Grams
	MCM 3.0L	3310-806078A 2	3/8" (10mm) Solid-Needle * 9/16" (14mm) Spring-Needle	1-3/32" (27 mm)	1-5/32" (29mm)	1 Lean clockwise	5/64" (2mm)	9 Grams
	MCM 3.0L	3310-807504A 1	3/8" (10mm) Solid-Needle * 9/16" (14mm) Spring-Needle	1-3/32" (27 mm)	1-5/32" (29mm)	1 Lean clockwise	5/64" (2mm)	9 Grams
	MCM 3.0L	3310-864940A01	3/8" (10mm) Solid-Needle * 9/16" (14mm) Spring-Needle	1-3/32" (27 mm)	1-5/32" (29mm)	1 Lean clockwise	5/64" (2mm)	9 Grams
	MCM 3.0L TKS	3310-866140A02	9/16" (14mm) Spring-Needle	1-3/32" (27 mm)				9 Grams
	MCM 3.0LX	1389-815397A 2	3/8" (10mm) Solid-Needle * 9/16" (14mm) Spring-Needle	1-3/32" (27 mm)	1-5/32" (29mm)	1 Lean clockwise	5/64" (2mm)	9 Grams
	MCM 3.0LX	3310-805924A 2	3/8" (10mm) Solid-Needle * 9/16" (14mm) Spring-Needle	1-3/32" (27 mm)	1-5/32" (29mm)	1 Lean clockwise	5/64" (2mm)	9 Grams
	MCM 470	1389-8489A 5	3/8" (10mm) Solid-Needle * 9/16" (14mm) Spring-Needle	1-3/32" (27mm)	1-5/32" (29mm)	INDEX	5/64" (2mm)	9 Grams
	MCM 170/165	1389-9564A 1	3/8" (10mm) Solid-Needle * 9/16" (14mm) Spring-Needle	1-3/32" (27mm)	1-5/32" (29mm)	INDEX	5/64" (2mm)	9 Grams
	MCM 165/3.7L	3310-806079A 2	3/8" (10mm) Solid-Needle * 9/16" (14mm) Spring-Needle	1-3/32" (27mm)	1-5/32" (29mm)	INDEX	5/64" (2mm)	9 Grams
MCM 165/3.7L	3310-860071A 2	3/8" (10mm) Solid-Needle * 9/16" (14mm) Spring-Needle	1-3/32" (27mm)	1-5/32" (29mm)	INDEX	5/64" (2mm)	9 Grams	
6	MCM 175/185	3304-9353A 2	3/8" (10mm) Solid-Needle * 9/16" (14mm) Spring-Needle	1-3/32" (27mm)	1-5/32" (29mm)	2 Lean clockwise	5/64" (2mm)	9 Grams
	MCM 175/4.3L	3304-9565A 1	3/8" (10mm) Solid-Needle * 9/16" (14mm) Spring-Needle	1-3/32" (27mm)	1-5/32" (29mm)	2 Lean clockwise	5/64" (2mm)	9 Grams
	MCM 4.3L	3304-9565A 7	3/8" (10mm) Solid-Needle * 9/16" (14mm) Spring-Needle	1-3/32" (27mm)	1-5/32" (29mm)	2 Lean clockwise	5/64" (2mm)	9 Grams
	MCM 4.3L	3310-806080A 2	3/8" (10mm) Solid-Needle * 9/16" (14mm) Spring-Needle	1-3/32" (27mm)	1-5/32" (29mm)	2 Lean clockwise	5/64" (2mm)	9 Grams
	MCM 4.3L	3310-806972A 1	9/16" (14mm) Spring-Needle	1-3/32" (27mm)	1-5/32" (29mm)	2 Lean clockwise	5/64" (2mm)	9 Grams
	MCM 4.3L	3310-807764A 1	9/16" (14mm) Spring-Needle	1-3/32" (27mm)	1-5/32" (29mm)	2 Lean clockwise	5/64" (2mm)	9 Grams
	MGM 4.3L	3310-864941A01	9/16" (14mm) Spring-Needle	1-3/32" (27mm)	1-5/32" (29mm)	2 Lean clockwise	5/64" (2mm)	9 Grams
	MCM 4.3L TKS	3310-866141A02	9/16" (14mm) Spring-Needle	1-3/32" (27 mm)				9 Grams
8	MCM 898/200	1389-8488A 2	3/8" (10mm) Solid-Needle * 9/16" (14mm) Spring-Needle	1-3/32" (27mm)	1-5/32" (29mm)	2 Lean clockwise	5/64" (2mm)	9 Grams
	MCM 200	1389-9563A 1	3/8" (10mm) Solid-Needle * 9/16" (14mm) Spring-Needle	1-3/32" (27mm)	1-5/32" (29mm)	2 Lean clockwise	5/64" (2mm)	9 Grams
	MCM 200/5.0L	1389-9670A 2	3/8" (10mm) Solid-Needle * 9/16" (14mm) Spring-Needle	1-3/32" (27mm)	1-5/32" (29mm)	2 Lean clockwise	5/64" (2mm)	9 Grams
	MCM 5.0L	3310-806081A 2	9/16" (14mm) Spring-Needle	1-3/32" (27mm)	1-5/32" (29mm)	2 Lean clockwise	5/64" (2mm)	9 Grams
	MCM 5.0L	3310-861080A 1	9/16" (14mm) Spring-Needle	1-3/32" (27mm)	1-5/32" (29mm)	2 Lean clockwise	5/64" (2mm)	9 Grams
	MCM 5.0L	3310-861448A 1	11/32" (9mm) Spring-Needle	15/16" (24mm)	1-5/32" (29mm)	2 Lean clockwise	5/64" (2mm)	9 Grams
	MCM 5.0L	3310-864942A03	11/32" (9mm) Spring-Needle	15/16" (24mm)	1-5/32" (29mm)	2 Lean clockwise	5/64" (2mm)	9 Grams
	MCM 5.0L TKS	3310-866142A03	11/32" (9mm) Spring-Needle	15/16" (24mm)				9 Grams
	MCM 5.7L	3310-807312A 1	9/16" (14mm) Spring-Needle	1-3/32" (27mm)	1-5/32" (29mm)	2 Lean clockwise	5/64" (2mm)	9 Grams
	MCM 5.7L	3310-861245A 1	11/32" (9mm) Spring-Needle	15/16" (24mm)	1-5/32" (29mm)	2 Lean clockwise	5/64" (2mm)	9 Grams
MCM 5.7L	3310-864943A01	11/32" (9mm) Spring-Needle	15/16" (24mm)	1-5/32" (29mm)	2 Lean clockwise	5/64" (2mm)	9 Grams	
MCM 5.7L TKS	3310-866143A03	11/32" (9mm) Spring-Needle	15/16" (24mm)				9 Grams	

* Note: On engines experiencing flooding or rough idle, if all components and specifications are okay, it may be necessary to change to the spring-loaded needle & seat assembly. Installing a spring loaded needle and seat on a 4-cylinder engine can cause a lean out condition in extremely hard turns. (GM 153, 181 cid: Right turn.) (Mercury Marine 224 cid: Left turn.)
Because of this potential lean out condition in extremely hard turns, you should make the boat owner aware of this condition before installing the spring-loaded needle and seat kit. The spring loaded needle and seat kit is the preferred one to use if you have a flooding problem at idle RPM. See MerCruiser Service Bulletin 97-8 for further information.

ADJUSTMENTS

SEE DATA TABLE FOR MEASUREMENTS

① TURN AIR HORN UPSIDE DOWN. PIVOT FLOAT ASSEMBLY UP AND DOWN ON HINGE PIN TO ENSURE IT MOVES FREELY.

IMPORTANT: BEFORE CHECKING FLOAT LEVEL, RAISE FLOAT AND ALLOW IT TO FALL; HOWEVER DO NOT FORCE DOWNWARD BY HAND.

② WITH GASKET IN PLACE, MEASURE FLOAT LEVEL FROM THE GASKET TO THE TOE OF THE FLOAT.

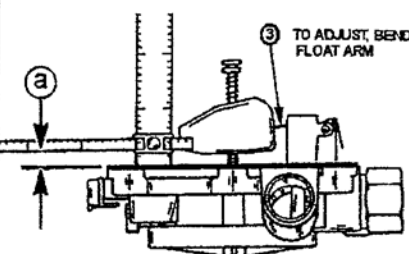

③ TO ADJUST, BEND FLOAT ARM

a - MEASURE FROM DOT ON FLOAT TO GASKET (SEE FIG. 2)

DRY FLOAT LEVEL ADJUSTMENT

FIG. 1

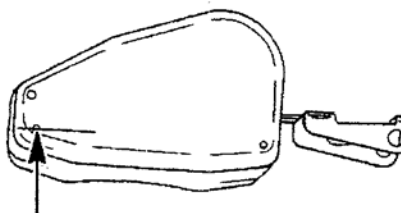

a - TOE OF FLOAT

FLOAT TOE LOCATION

FIG. 2

① HOLD AIR HORN RIGHT SIDE UP TO ALLOW FLOAT TO HANG FREE.

② WITH GASKET IN PLACE, MEASURE FLOAT DROP FROM THE GASKET TO THE TOE OF THE FLOAT.

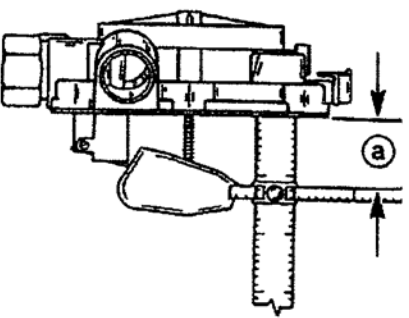

a - MEASURE FROM DOT ON FLOAT TO GASKET (SEE FIG. 2)

FLOAT DROP ADJUSTMENT

FIG. 3

② MEASURE DISTANCE BETWEEN FLAME ARRESTOR MOUNTING SURFACE TO TOP OF PUMP ROD.

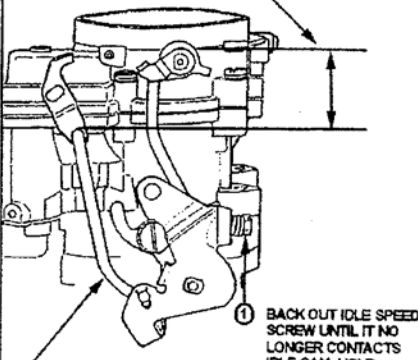

③ TO ADJUST, BEND PUMP ROD

① BACK OUT IDLE SPEED SCREW UNTIL IT NO LONGER CONTACTS IDLE CAM. HOLD THROTTLE VALVES CLOSED TIGHTLY.

PUMP ROD ADJUSTMENT

FIG. 4

① HOLD THROTTLE VALVES COMPLETELY OPEN.

② GENTLY PRESS DOWN CHOKE PLATE TOWARD CLOSED POSITION. MEASURE BETWEEN UPPER EDGE OF CHOKE PLATE AND INNER AIR HORN WALL.

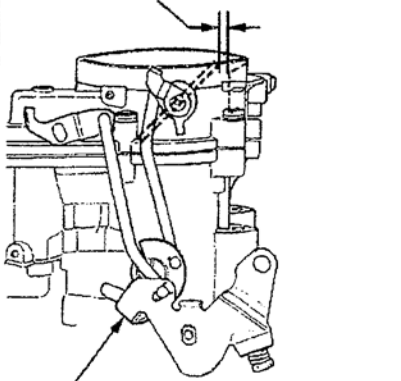

③ TO ADJUST, BEND TANG

CHOKE UNLOADER ADJUSTMENT

FIG. 5

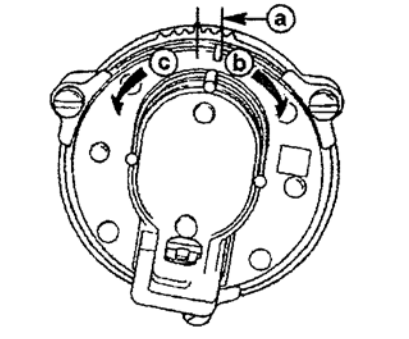

a - SCRIBED MARK IN COVER ROTATED CLOCKWISE TWO POSITIONS FROM CENTER INDEX

b - CLOCKWISE = LEANER

c - COUNTER-CLOCKWISE = RICHER

CHOKE SETTING

FIG. 6