

# INSTRUCTION SHEET

## OFF VEHICLE CARBURETOR SERVICE

### CARTER-MODEL RBS

50-733

#### GENERAL EXPLODED VIEW

THE GENERAL DESIGN AND PARTS SHOWN WILL VARY TO  
INDIVIDUAL UNITS COVERED ON THIS INSTRUCTION SHEET

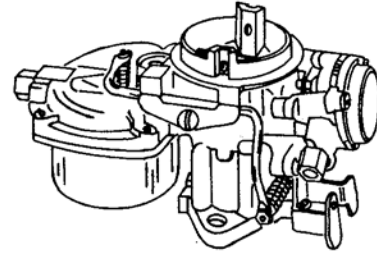
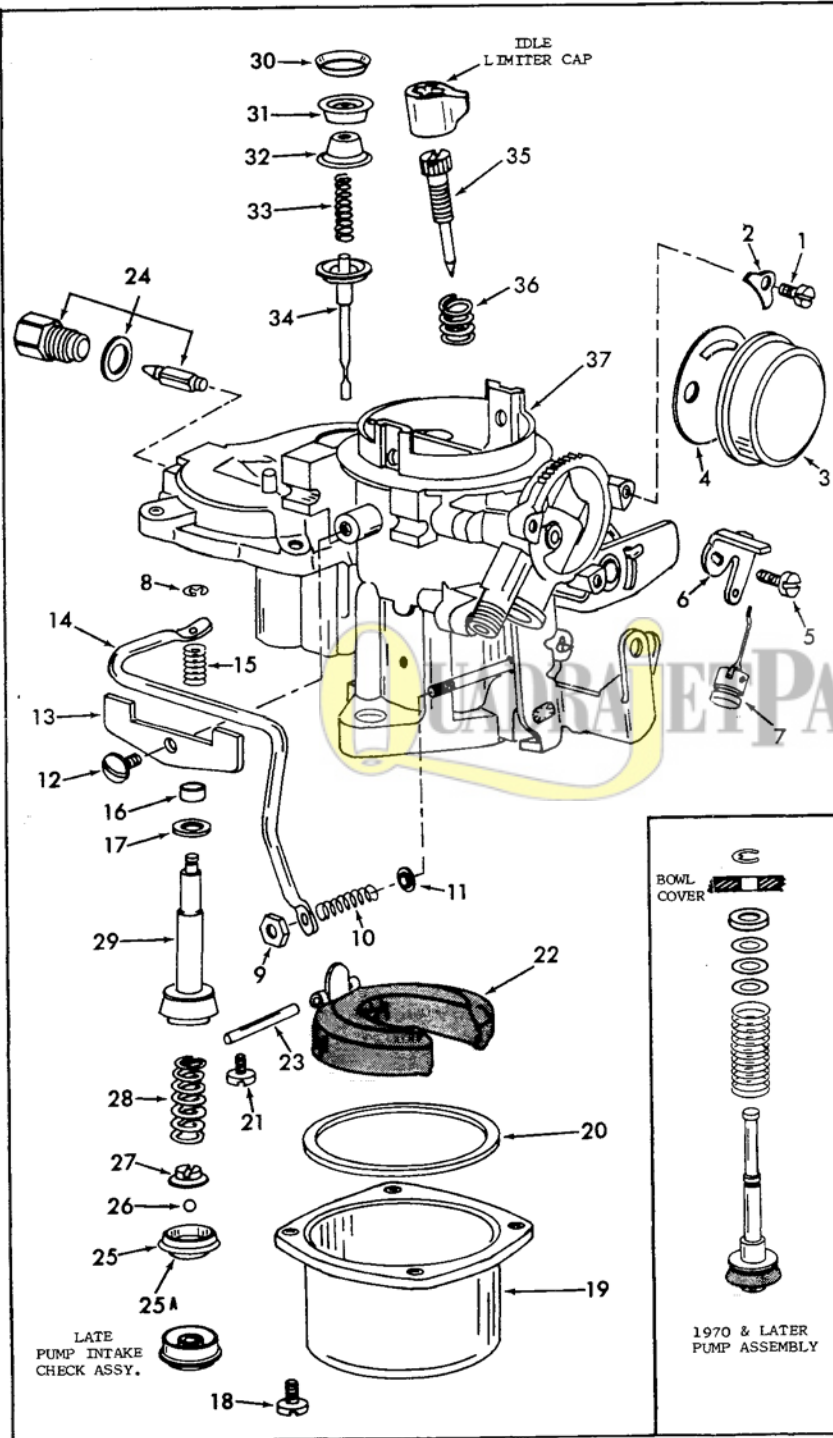

#### DISASSEMBLY

USE EXPLODED VIEW AS A GUIDE. THE NUMERICAL SEQUENCE MAY GENERALLY BE FOLLOWED TO DISASSEMBLE UNIT FAR ENOUGH TO PERMIT CLEANING AND INSPECTION.

NOTE: PUMP PLUNGER (29) REMOVAL. PRESS TO BOTTOM OF PUMP CYLINDER THEN TAP LIGHTLY ON PUMP SHAFT TO REMOVE PARTS (25), (26), (27), (28), (29). TO REMOVE STEP UP ROD AND DIAPHRAGM (34). PRY OUT WASHER (30) THEN PIERCE DIAPHRAGM COVER (31) NEAR OUTER EDGE WITH SMALL PUNCH OR SCREW DRIVER AND PRY OUT COVER (31). NOTE: REMOVE RUBBER VENT VALVE ON 68-69 MODELS BEFORE CLEANING.

#### NOMENCLATURE

REF. NO.	REF. NO.
1. SCREW - STAT COVER (3)	22. FLOAT & LEVER ASSY.
2. RETAINER - STAT COVER	23. PIN - FLOAT LEVER
3. STAT COVER	24. NEEDLE, SEAT & GASKET ASSY.
4. GASKET STAT COVER	25. SEAT - (WITH HOLE) INTAKE BALL CHECK (SOME MODELS)
5. SCREW - CHOKE PISTON LEVER	25A. RETAINER - (SOLID) PUMP CYLINDER (SOME MODELS)
6. LEVER - CHOKE PISTON	26. BALL - INTAKE CHECK (SOME MODELS)
7. PISTON & LINK - CHOKE	27. RETAINER - INTAKE CHECK BALL (SOME MODELS)
8. RETAINER - PUMP ROD	28. SPRING - PUMP (LOWER)
9. NUT - PUMP ARM CONNECTOR LINK	29. PLUNGER - PUMP
10. PUMP ARM CONNECTOR LINK	30. WASHER - CONICAL
11. RETAINER - PUMP ARM CONNECTOR LINK SPRING	31. COVER - STEP UP ROD
12. SCREW - PUMP ARM RETAINER	32. DIAPHRAGM
13. RETAINER - PUMP ARM	33. RETAINER - STEP UP ROD
14. PUMP ARM	33. ROD DIAPHRAGM
15. SPRING - PUMP (UPPER)	34. SPRING - STEP UP ROD
16. BUSHING - PUMP PLUNGER SHAFT (SOME MODELS)	34. STEP UP ROD & DIAPHRAGM ASSY.
17. WASHER - PUMP	35. NEEDLE - IDLE ADJUSTING
18. SCREW - BOWL ATTACHING (4)	36. SPRING - IDLE ADJUSTING NEEDLE
19. BOWL - FUEL	37. MAIN BODY ASSY.
20. GASKET - FUEL BOWL	
21. SCREW - FLOAT PIN (2)	

#### CLEANING

CLEANING MUST BE DONE WITH CARBURETOR DISASSEMBLED. SOAK PARTS LONG ENOUGH TO SOFTEN AND REMOVE ALL FOREIGN MATERIAL. USE (1) A CARBURETOR CLEANING SOLVENT, (2) LACQUER THINNER OR (3) DENATURATED ALCOHOL. MAKE CERTAIN THE THROTTLE BORE IS FREE OF ALL HARD CARBON DEPOSITS. WASH OFF IN SUITABLE SOLVENT. BLOW OUT ALL PASSAGES IN CASTING WITH COMPRESSED AIR AND CHECK CAREFULLY TO INSURE THOROUGH CLEANING OF OBSCURE AREAS. CAUTION: DO NOT SOAK RUBBER, LEATHER OR PLASTIC PARTS IN SOLVENT.

#### REASSEMBLY

REASSEMBLE IN REVERSE ORDER OF DISASSEMBLY. NOTE SPECIAL INSTRUCTIONS AND FOLLOW NUMERICAL OUTLINE IN MAKING ADJUSTMENTS NECESSARY FOR CARBURETOR BEING SERVICED.

#### SPECIAL INSTRUCTIONS

IDLE MIXTURE ADJUSTING NEEDLE (35). LIGHTLY BOTTOM THEN BACK OUT 1 1/4 TURNS.

A. STEP UP ROD TO DIAPHRAGM ASSEMBLY (34). SEE FIG. 1.  
B. PLACE STEP UP ROD AND DIAPHRAGM ASSEMBLY (34) IN POSITION. USING HAT SHAPED RETAINER (32), PRESS DIAPHRAGM DOWN IN PLACE AGAINST GASKET LEDGE IN CASTING. REMOVE RETAINER AND EXAMINE FOR EVEN ASSEMBLY. INSTALL (33), (32) AND NEW DIAPHRAGM COVER (31) USING A 5/8" SOCKET AS A DRIFT AND TAP IN PLACE WITH A HAMMER. NEXT INSTALL CONICAL WASHER (30) WITH SMALL OPENING DOWN USING A 1/2" SOCKET AS A DRIFT TAP WITH HAMMER UNTIL WASHER IS DRIVEN INTO COVER 3/32" TO 1/8" BELOW TOP EDGE OF COVER. CAUTION: DO NOT STRIKE CENTER OF COVER OR DRIVE CONICAL WASHER IN BEYOND 1/8".

PUMP PLUNGER (29) - REMOVE PAPER SLEEVE FROM LEATHER CUP IF USED. FLEX LEATHER CUP OUTWARD SLIGHTLY. SOAK CUP IN GASOLINE, KEROSENE OR OIL FOR A FEW MINUTES PRIOR TO PLACING IN CARBURETOR.

# ADJUSTMENTS

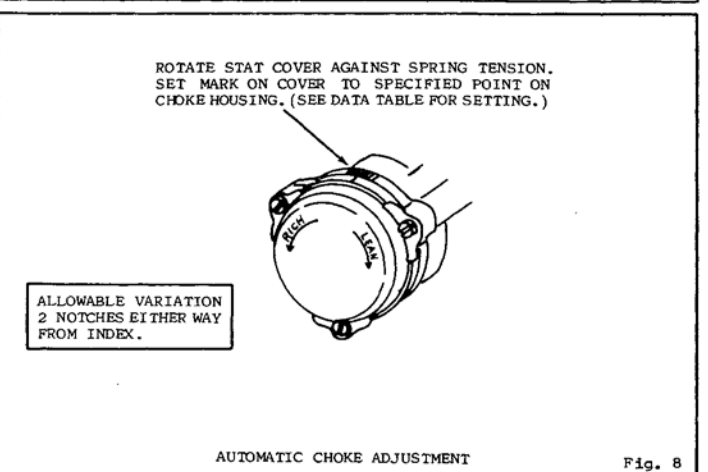
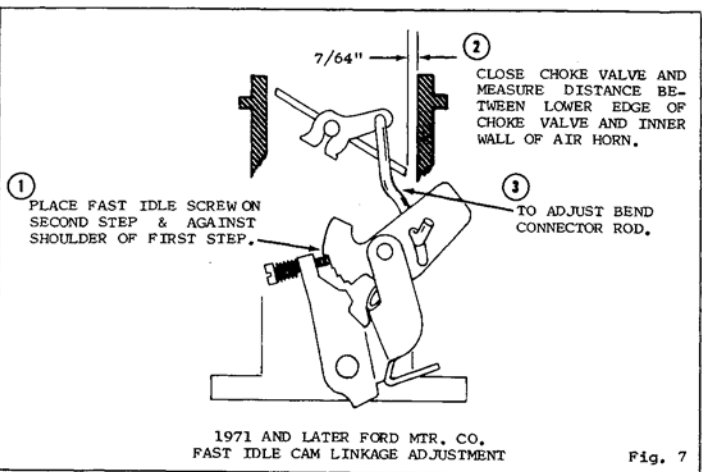
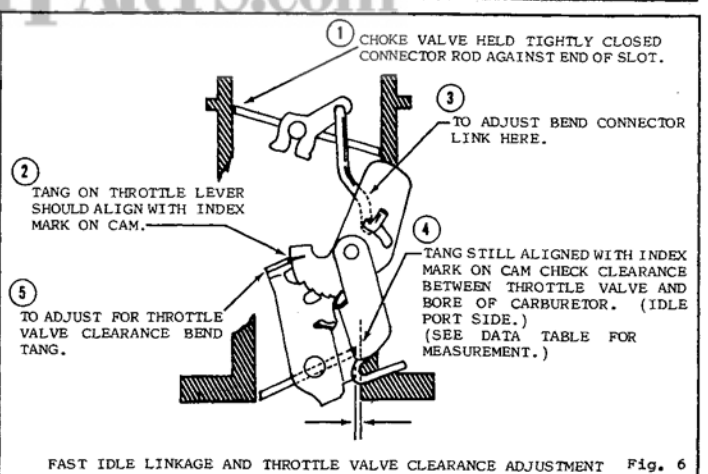
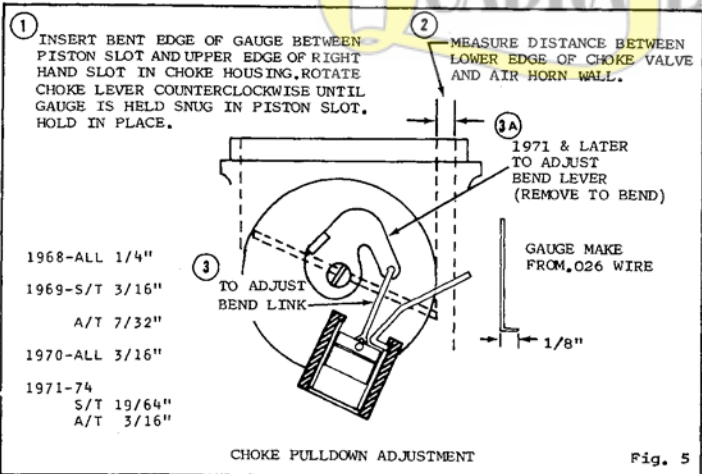
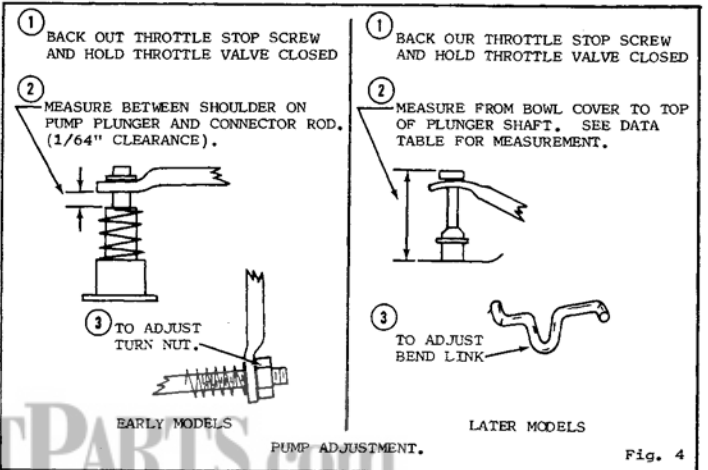
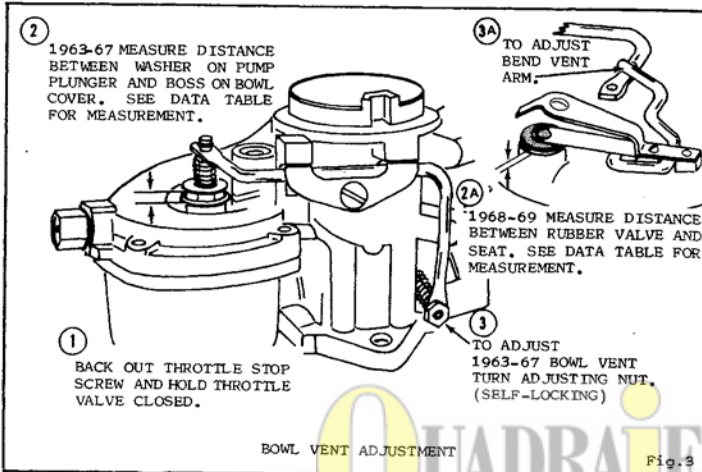
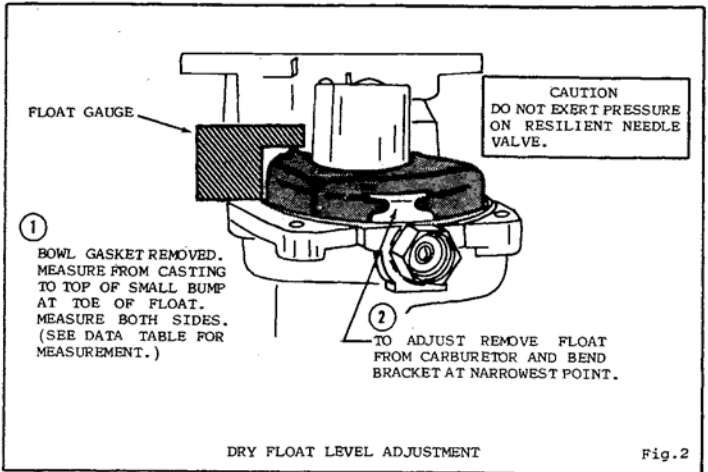
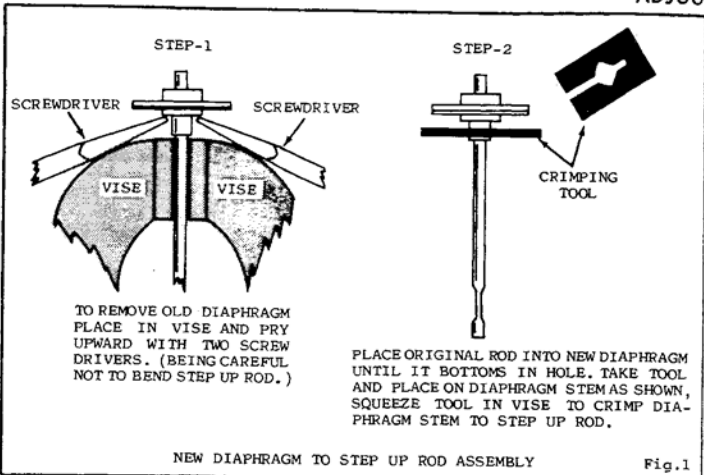

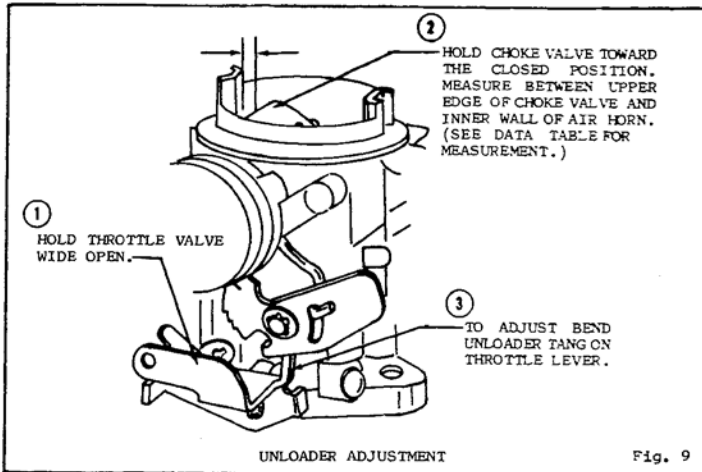

Fig. 9

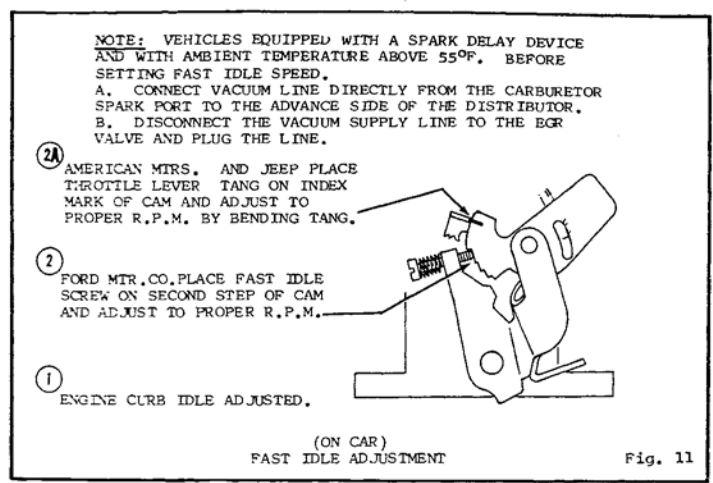

Fig. 11

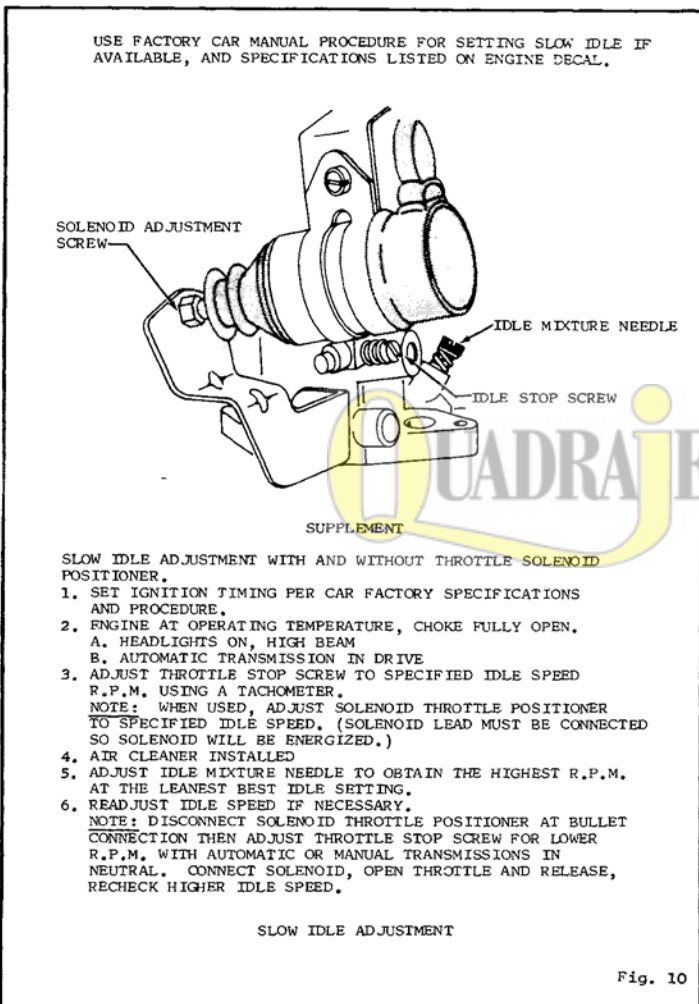

Fig. 10

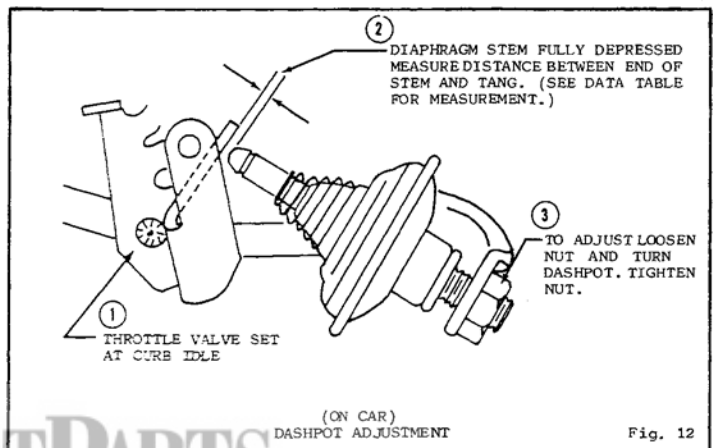

Fig. 12

# ADJUSTMENT DATA TABLE

YEAR	MAKE	FLOAT LEVEL	BOWL VENT OR PUMP ADJ.	FAST IDLE LINKAGE ADJ.	FAST IDLE THROTTLE VALVE CLEARANCE	AUTO CHOKE SETTING	UNLOADER ADJ.	SLOW IDLE RPM	FAST IDLE RPM	DASH POT ADJ.
1963-65	AMERICAN MTRS. 195.6" ENG.	15/32"	1/16"	INDEX	1/32"	INDEX	1/8"	550N-AC/ON	1750-2000	3/32"-1/8"
1965-67	AMERICAN MTRS. 199" ENG.	15/32"	1/16"	INDEX	3/64"	1-RICH	1/8"	550N-AC/ON	1750-2000	----
1965-67	AMERICAN MTRS. 232" ENG.	15/32"	1/16"	INDEX	1/32"	1-RICH	1/8"	550N-AC/ON	1750-2000	----
1968-69	AMERICAN MTRS. 232" ENG.	9/16"	5/64"B/V	INDEX	1/32"	A/T-2 RICH	1/8"	A/T 525DR.	2000	----
1969	AMERICAN MTRS. 199" ENG.	9/16"	5/64"B/V	INDEX	1/32"	S/T-INDEX	3/16"	S/T 600	2000	----
						A/T-2 RICH		A/T 625DR.	2000	----
						S/T-INDEX		S/T 600	2000	----
1970	FORD MTR. CO. 250" ENG.	9/16"	1 3/8"P/A	INDEX	3/64"	A/T-1 RICH	9/32"	A/T 600/500 <sup>2</sup>	----	3/32"
1971	FORD MTR. CO. 250" ENG.	9/16"	1 3/8"P/A	1/8"	----	S/T-INDEX	9/32"	S/T 750/500 <sup>2</sup>	1600	----
						A/T-1 RICH		A/T 550DR.		3/32"
						S/T-INDEX		A/T 600/500 <sup>2</sup>	1600	----
1972-73	FORD MTR. CO 250" ENG.	9/16"	1 3/8"P/A	1/8"	----	A/T-1 RICH	9/32"	ENG. DECAL <sup>2</sup>	1600	----
						S/T-INDEX	1/4"	ENG. DECAL <sup>2</sup>	1600	----
1974	FORD MTR. CO 250" ENG.	9/16"	1 3/8"P/A	1/8"	----	A/T-1 RICH	1/4"	ENG. DECAL <sup>2</sup>	1600	----
						INDEX	1/4"	ENG. DECAL <sup>2</sup>	S/T 1600	----
								A/T 1700		----
1966-71	KAISER JEEP 232" ENG.	21/32"	1/16"	INDEX	A/CHOKE 1/32" M/CHOKE 3/64"	1-RICH	1/8"	600-675	1800	5/32"-1/8"
1963-64	STUDEBAKER 6 CYL.	15/32"	1/16"	INDEX	3/64"	INDEX	3/16"	550 N	----	----

A/T = AUTOMATIC TRANSMISSION  
 S/T = STANDARD TRANSMISSION  
 N = NEUTRAL  
 AC = AIR COND.  
 DR. = IN DRIVE

<sup>2</sup>NOTE: A/T IN DR. LIGHTS ON HIGH BEAM  
 HIGHER R.P.M. (SOLENOID ENERGIZED)  
 LOWER R.P.M. (SOLENOID NOT-ENERGIZED)

## MARINE ADJUSTMENTS

	FLOAT LEVEL	PUMP ADJ.	UNLOADER	CHOKE SETTING	SLOW IDLE R. P. M.
KIEKHAEFER MERCURY MARINE (STERN DRIVE) MCM 80 4 CYL. 89.7" ENG. CARB. NO. 4394	3/8"	.015"	7/64"	4 LEAN	650
OUTBOARD MARINE OMC 120 4 CYL. (DUAL CARBS.)					
CARB. NO. 3971	15/32"	.015"	7/64"	INDEX	600
CARB. NO. 4208	15/32"	.015"	7/64"	INDEX	600
OMC 150 V6 CYL.					
CARB. NO. 3951	15/32"	.015"	7/64"	INDEX	600
OMC 155 V6 CYL.					
CARB. NO. 4207	15/32"	.015"	7/64"	INDEX	600