

INSTRUCTION SHEET

HOLLEY CARBURETOR - MODELS 1904, 1960, 1908

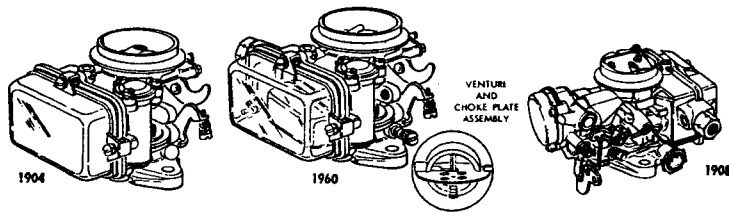

GENERAL EXPLODED VIEW

THE GENERAL DESIGN AND PARTS SHOWN WILL VARY TO INDIVIDUAL UNITS COVERED ON THIS INSTRUCTION SHEET

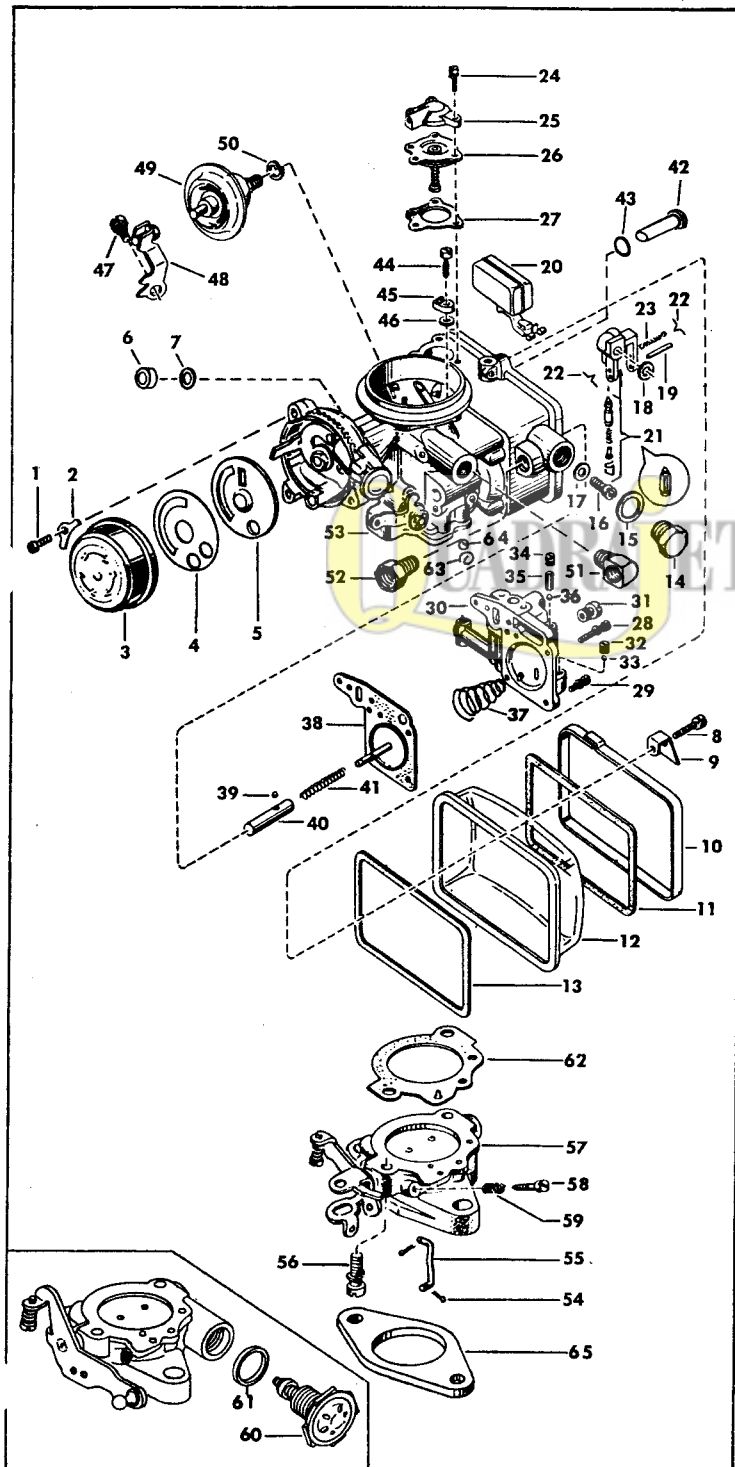

DISASSEMBLY

USE EXPLODED VIEW AS A GUIDE. THE NUMERICAL SEQUENCE MAY GENERALLY BE FOLLOWED TO DISASSEMBLE UNIT FAR ENOUGH TO PERMIT CLEANING AND INSPECTION. NOTE: IF NECESSARY TO REMOVE CHOKE HOUSING, CHOKE SHAFT SEAL (6) AND CHOKE HOUSING GASKET (7) SHOULD BE REPLACED. TO REMOVE SLEEVE (40) FROM STEM OF DIAPHRAGM (38), COMPRESS SLEEVE (40) AND SPRING (41) SO BALL (39) CAN DROP OUT OF HOLE. THE SLEEVE AND SPRING WILL THEN SLIDE OFF DIAPHRAGM SHAFT.

NOMENCLATURE

REF. NO.	REF. NO.
1. SCREW(3)-STAT COVER RETAINER	32. PLUG-PUMP INLET BALL
2. RETAINER(3)-STAT COVER	33. BALL-PUMP INLET
3. STAT COVER & SPRING ASSY.	34. PLUG-PUMP DISCH. BALL
4. GASKET-STAT COVER	35. WEIGHT-PUMP DISCH. BALL
5. PLATE-CHOKE BAFFLE	36. BALL-PUMP DISCHARGE
6. SEAL-CHOKE SHAFT	37. SPRING-PUMP RETURN
7. GASKET-CHOKE HOUSING	38. PUMP DIAPH. & GASKET ASSY.
8. SCREW(4)-FUEL BOWL CLAMP	39. BALL-PUMP SLEEVE RETAINER
9. CLAMP(4)-FUEL BOWL	40. SLEEVE-PUMP PUSH ROD
10. RING-FUEL BOWL CLAMP	41. SPRING-PUMP OPERATING
11. GASKET-FUEL BOWL CLAMP RING	42. NOZZLE TUBE(MODEL 1960)
12. BOWL-FLOAT	43. O-RING - NOZZLE TUBE (MODEL 1960)
13. GASKET-FLOAT BOWL	44. SCREW-PUMP DISCH. NOZZLE
14. FUEL INLET FITTING, PLUG OR NEEDLE SEAT	45. NOZZLE-PUMP DISCHARGE
15. GASKET-PLUG OR NEEDLE SEAT	46. GASKET-PUMP DISCH. NOZZLE
16. SCREW-FUEL INLET SEAT	47. SCREW-DASHPOT LEVER
17. GASKET-FUEL INLET SEAT SCREW	48. LEVER-DASHPOT
18. GASKET-FUEL INLET SEAT	49. DASHPOT ASSY.
19. PIN-FLOAT HINGE	50. LOCKWASHER-DASHPOT ASSY.
20. FLOAT & LEVER ASSY.	51. FITTING-DIST. LINE
21. NEEDLE & SEAT ASSY. (SOLID NEEDLE SOME MODELS)	52. FITTING-FUEL INLET
22. RETAINER(2)-FLOAT BUMPER SPRING	53. MAIN BODY ASSY.
23. SPRING-FLOAT BUMPER	54. RETAINER-PUMP LINK
24. SCREW(3)-ECONOMIZER COVER	55. LINK-PUMP
25. COVER-ECONOMIZER DIAPHRAGM	56. SCREW(2)-THROTTLE BODY TO MAIN BODY
26. ECONOMIZER DIAPHRAGM ASSY.	57. THROTTLE BODY ASSY.
27. GASKET-ECONOMIZER DIAPH.	58. NEEDLE-IDLE ADJUSTING
28. SCREW(2) LONG-MAIN WELL BODY ASSY.	59. SPRING-IDLE ADJ. NEEDLE
29. SCREW(3) SHORT-MAIN WELL BODY ASSY.	60. VALVE-SPARK
30. MAIN WELL & ECON. BODY ASSY.	61. GASKET-SPARK VALVE
31. JET-MAIN METERING	62. GASKET-BODY FLANGE
	63. RETAINER-DIST. CHECK BALL
	64. BALL-DISTRIBUTOR CHECK
	65. GASKET-FLANGE

CLEANING

CLEANING MUST BE DONE WITH CARBURETOR DISASSEMBLED. SOAK PARTS LONG ENOUGH TO SOFTEN AND REMOVE ALL FOREIGN MATERIAL. USE (1) A CARBURETOR CLEANING SOLVENT, (2) LACQUER THINNER OR (3) DENATURED ALCOHOL. MAKE CERTAIN THE THROTTLE BODY IS FREE OF ALL CARBON DEPOSITS. WASH OFF IN SUITABLE SOLVENT. BLOW OUT ALL PASSAGES IN CASTINGS WITH COMPRESSED AIR AND CHECK CAREFULLY TO INSURE THOROUGH CLEANING OF OBSCURE AREAS.

CAUTION: DO NOT SOAK ANY PARTS CONTAINING RUBBER, LEATHER OR PLASTIC IN CLEANING SOLVENT.

REASSEMBLY

REASSEMBLE IN REVERSE ORDER OF DISASSEMBLY. NOTE SPECIAL INSTRUCTIONS AND FOLLOW NUMERICAL OUTLINE IN MAKING ADJUSTMENTS. SEE OTHER SIDE.

SPECIAL INSTRUCTIONS

USE FLOAT BUMPER SPRING (23) AND RETAINER CLIPS (22) FROM OLD ASSEMBLY WHERE PREVIOUSLY USED.

SOME CARBURETORS WERE EQUIPPED WITH A SPRING LOADED FUEL INLET NEEDLE AND SOME WITH A SOLID NEEDLE. EITHER TYPE MAY BE USED AS SUPPLIED IN KIT.

SLIDE SPRING (41) AND SLEEVE (40) ON THE STEM OF PUMP DIAPHRAGM ASSEMBLY (38). WITH HOLE IN SLEEVE IN LINE WITH NOTCH ON STEM, DROP BALL (39) INTO HOLE IN SLEEVE AND RELEASE SLOWLY.

TIGHTEN SCREWS (8) PROGRESSIVELY AND EVENLY TO PREVENT STRAIN ON BOWL.

IDLE ADJUSTING NEEDLE (58). TURN NEEDLE IN LIGHTLY UNTIL SEATED. THEN BACK OUT 1 TURN.

ADJUSTMENTS

YEAR	MAKE	FLOAT LEVEL
1959-60	AMERICAN MTRS. 196" ENG.	9/32"
1961-62	AMERICAN MTRS. 196" ENG.	21/64"
1960-61	COMET 6 CYL. 144"-170" ENG.	9/32"
1959-60	EDSEL 6 CYL. 223" ENG.	9/32"
1960-61	FALCON 6 CYL. 144"-170" ENG.	9/32"
1952-64	FORD 6 CYL. 215"-223" ENG.	9/32"
1952-62	FORD TRUCK 6 CYL. 144"-170"-213"-215" ENG.	9/32"
1961-63	FORD TRUCK 6 CYL. 223"-262" ENG.	3/8 "
	GMC TRUCK 6 CYL. 248"-270" ENG.	3/8 "
	GMC TRUCK V6 305A ENG.	13/64"
1953-58	INTERNATIONAL TRUCK 6 CYL	3/8 "
	INTERNATIONAL HARVESTER SCOUT 4 CYL.	3/8 "
1961-62	MERCURY 223" ENG.	9/32"

DATA TABLE

