

INSTRUCTION SHEET

OFF VEHICLE CARBURETOR SERVICE

HOLLEY MODEL-4180C

DISASSEMBLY

USE THE EXPLODED VIEW AS A GUIDE. THE NUMERICAL SEQUENCE MAY GENERALLY BE FOLLOWED TO DISASSEMBLE UNIT FAR ENOUGH TO PERMIT CLEANING AND INSPECTION. NOTE: THE CHOKE PLATE RETAINING SCREWS ARE STAKED AT THE THREADED END AND THIS STAKING MUST BE FILED OFF BEFORE REMOVING SCREWS. (BE CAREFUL NOT TO DAMAGE THE CHOKE SHAFT OR VENTURI WHILE FILING THE SCREWS.)

TO REMOVE CHOKE COVER RETAINER TAMPER PROOF SCREWS, CAREFULLY HACK-SAW A SLOT IN THE HEAD OF THE SCREW DEEP ENOUGH TO ACCOMMODATE A SCREW-DRIVER BIT. CAREFULLY REMOVE THE SCREWS WITH A SCREWDRIVER.

IDENTIFY PRIMARY AND SECONDARY FLOATS AS THEY ARE REMOVED FROM THE FUEL BOWLS, FOR PROPER REASSEMBLY.

TO REMOVE PRIMARY AND SECONDARY IDLE MIXTURE CONCEALMENT PLUGS. CENTER PUNCH AND DRILL 3/32" DIAMETER HOLE THROUGH THE HARDENED STEEL PLUG. INSTALL AN EASY OUT AND REMOVE PLUG. BEFORE REMOVING IDLE ADJUSTING NEEDLES, CAREFULLY TURN NEEDLES IN CLOCKWISE COUNTING THE NUMBER OF TURNS IT TAKES TO LIGHTLY SEAT THE NEEDLES. (RECORD FOR PROPER REASSEMBLY).

CLEANING

CLEANING MUST BE DONE WITH CARBURETOR DISASSEMBLED. SOAK PARTS LONG ENOUGH TO SOFTEN AND REMOVE ALL FOREIGN MATERIAL USING A COLD IMMERSION TYPE CARBURETOR CLEANER. MAKE CERTAIN THE THROTTLE BORES ARE FREE OF ALL CARBON AND VARNISH DEPOSITS. RINSE OFF IN SUITABLE SOLVENT. BLOW OUT ALL PASSAGES IN CASTINGS WITH COMPRESSED AIR AND CHECK CAREFULLY TO INSURE THOROUGH CLEANING OF OBSCURE AREAS. CAUTION: DO NOT SOAK ASSEMBLIES WITH ATTACHED PLASTIC PARTS FOR A LONG PERIOD OF TIME. DO NOT SOAK ANY PARTS CONTAINING RUBBER, FLOATS, OR DIAPHRAGM ASSYS.

REASSEMBLY

REASSEMBLE IN REVERSE ORDER OF DISASSEMBLY. NOTE SPECIAL INSTRUCTIONS AND FOLLOW NUMERICAL OUTLINE IN MAKING ADJUSTMENTS NECESSARY FOR CARBURETOR BEING SERVICED.

SPECIAL INSTRUCTIONS

PUMP DISCHARGE CHECK NEEDLE (79)-REPLACE WITH STEEL BALL. INSTALL BALL THEN USING A BRASS PUNCH AND HAMMER LIGHTLY STAKE BALL FOR A GOOD SEAT.

PUMP NOZZLE (78) AND SCREW (76) INSTALLATION-TIGHTEN SCREW SECURELY. USING A FLAT PUNCH AND HAMMER, RESTAKE THE NOZZLE SCREW IN POSITION. (CARE SHOULD BE USED WHEN STAKING THE NOZZLE SO AS NOT TO USE EXCESSIVE FORCE. REMOVE ANY CHIPS FROM CARBURETOR BODY. SEE FIG. 1.

CHOKE PLATE SCREWS (71)-STAKE SCREWS AFTER INSTALLATION.

PRIMARY IDLE ADJUSTING NEEDLES (67)-TURN IN UNTIL LIGHTLY SEATED, THEN BACK OUT NUMBER OF TURNS RECORDED ON DISASSEMBLY. (DO NOT INSTALL IDLE NEEDLE CONCEALMENT PLUGS AT THIS TIME.)

SCREWS LISTED BELOW MUST BE TIGHTENED IN THREE STAGES CROSSWISE TO ARRIVE AT THE CORRECT TORQUE.

THROTTLE BODY GASKET (65)-BE SURE HOLES ARE PROPERLY MATCHED TO THROTTLE BODY. TORQUE THROTTLE BODY SCREWS TO 50 INCH LBS.

ENRICHMENT VALVE (58)-INSTALL WITH GASKET AND TORQUE TO 100 INCH LBS.

PRI. AND SEC. FUEL BOWL (43) (23)-BEFORE INSTALLING MAKE DRY FLOAT LEVEL ADJUSTMENT.

BOWL SCREW INSTALLATION (41) (21)-INSTALL GASKETS (42) (22) ON SCREWS BEFORE INSTALLING, THEN TORQUE EVENLY IN STAGES TO 50 INCH LBS.

FUEL LINE TUBE (35)-INSTALL O-RINGS (36) ON THE EXTREME ENDS OF THE TUBE, THEY WILL ROLL ON THE TUBE WHEN INSTALLING THE FUEL BOWLS.

O-RINGS-LUBRICATE LIGHTLY BEFORE INSTALLING.

NOMENCLATURE

REF.
NO.

1. SCREW (2)-SOLO POT
2. SOLO POT ASSY.
3. SCREW (2)-RETAINER
4. SCREW (1)-RETAINER
5. RETAINER-CHOKE COVER
6. CHOKE COVER ASSY.
7. GASKET-CHOKE COVER
8. RETAINER-CHOKE ROD
9. SCREW & LKWSHR. (3)-CHOKE HOUSING
10. CHOKE HOUSING ASSY.
11. GASKET-CHOKE HOUSING (O-RING 1984-85)
12. RETAINER-SEC. DIAPHRAGM LINK
13. SCREW & LKWSHR. (3)-SEC. DIAPH. HSG.
14. SEC. DIAPHRAGM HSG. ASSY.
15. GASKET-SEC. DIAPH. HSG. (O-RING 1984-85)
16. SCREW & LKWSHR. (4)-COVER
17. COVER-SEC. DIAPHRAGM
18. SPRING-SEC. DIAPHRAGM
19. DIAPHRAGM-SECONDARY
20. BALL-SEC. DIAPHRAGM CHECK
21. SCREW (4)-SEC. FUEL BOWL
22. GASKET (4)-SEC. BOWL SCREW
23. BOWL ASSY.-SEC. FUEL
24. NEEDLE & SEAT ASSY.-SEC.
25. BAFFLE-SEC. FUEL
26. RETAINER-SEC. FLOAT
27. FLOAT & SPRING ASSY.-SEC.
28. PLUG-FUEL LEVEL
29. GASKET-PLUG
30. SCREW (6)-SEC. METERING BODY
31. METERING BODY-SEC.
32. GASKET-METERING BODY
33. PLATE-METERING BODY
34. GASKET-FUEL BOWL & METERING BODY
35. TUBE-FUEL LINE
36. O-RING (2)-FUEL LINE TUBE
37. SCREW & LKWSHR. (4)-PUMP COVER
38. COVER ASSY.-PUMP DIAPHRAGM
39. DIAPHRAGM-PUMP
40. SPRING-PUMP DIAPHRAGM
41. SCREW (4)-PRI. FUEL BOWL
42. GASKET (4)-PRI. BOWL SCREW
43. BOWL ASSY.-PRIMARY
44. NEEDLE & SEAT ASSY.-PRI.
45. BAFFLE-PRI. FUEL
46. RETAINER-PRI. FLOAT
47. FLOAT & SPRING ASSY.-PRI.
48. PLUG-FUEL LEVEL
49. GASKET-PLUG
50. FITTING-FUEL INLET
51. GASKET-FITTING
52. GASKET-FILTER
53. FILTER-FUEL
54. SPRING-FILTER
55. GASKET-PRI. FUEL BOWL
56. METERING BODY-PRI.
57. JET (2)-MAIN
58. VALVE-PRI. ENRICHMENT
59. GASKET-PRI. ENRICHMENT VALVE
60. GASKET-PRI. METERING BODY
61. TUBE-PUMP PASSAGE
62. O-RING (2)-PASSAGE TUBE
63. SCREW & LKWSHR. (6)-THROTTLE BODY
64. THROTTLE BODY ASSY.
65. GASKET-THROTTLE BODY
66. PLUG (2)-PRI. IDLE NEEDLE
67. NEEDLE (2)-PRI. IDLE ADJUSTING
68. O-RING (2)-PRI. IDLE NEEDLE
69. SPRING (2)-PRI. IDLE ADJ. NEEDLE
70. MAIN BODY ASSY.
71. SCREW (2)-CHOKE PLATE
72. PLATE-CHOKE
73. SHAFT-CHOKE PLATE
74. ROD-CHOKE
75. SEAL-CHOKE ROD
76. SCREW-PUMP NOZZLE
77. GASKET (2)-PUMP NOZZLE
78. NOZZLE-PUMP DISC.
79. NEEDLE-PUMP DISC. CHECK

ADJUSTMENTS

FLOAT BOWL INVERTED, TURN NEEDLE SEAT ASSEMBLY UNTIL FLOAT SURFACE IS PARALLEL WITH THE SURFACE DIRECTLY BELOW THE FLOAT. TIGHTEN LOCK NUT.

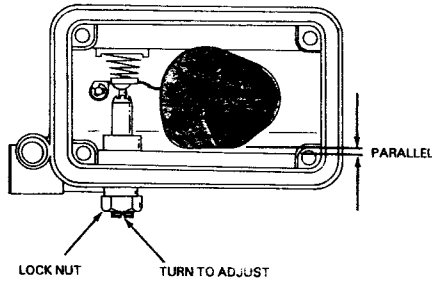

PRIMARY & SECONDARY
DRY FLOAT LEVEL
ADJUSTABLE NEEDLE & SEAT

FIG. 1

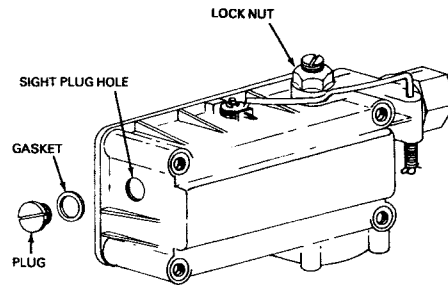

1. VEHICLE SITTING ON LEVEL SURFACE AND ENGINE RUNNING.
2. REMOVE SIGHT LEVEL PLUG FROM HOLE.
3. ADJUST NEEDLE SEAT ASSEMBLY SO FUEL WILL BE AT BOTTOM EDGE OF SIGHT PLUG HOLE. (1/32" TOLERANCE.)
4. TIGHTEN LOCK NUT.

WET FLOAT LEVEL
ADJUSTABLE NEEDLE & SEAT

FIG. 2

SAFETY "O" RING SEAL MUST BE SNUG AGAINST BOWL. ADJUSTMENT SCREW SLOT

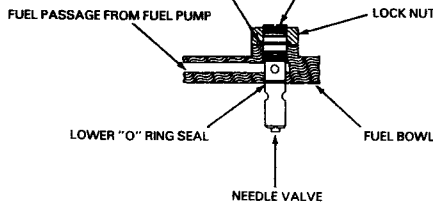

THE EXCLUSIVE SEALING FEATURE OF THIS ASSEMBLY PROVIDE SAFE ADJUSTMENT OF FUEL LEVEL WHILE ENGINE IS RUNNING.

SAFETY SEAL ADJUSTABLE FUEL VALVE

FIG. 3

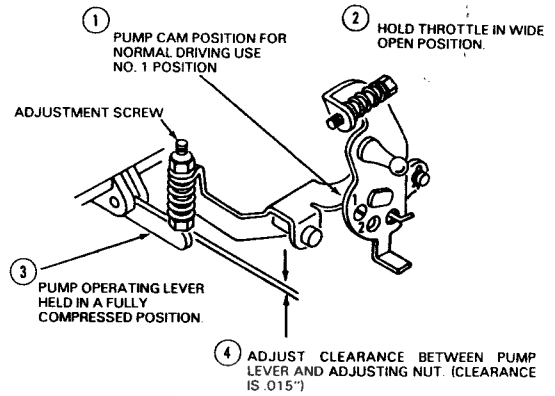

PUMP ADJUSTMENT

FIG. 4

SECONDARY THROTTLE STOP SCREW, BACK OUT UNTIL SECONDARY PLATES ARE CLOSED. TURN SCREW IN UNTIL IT CONTACTS STOP. THEN TURN SCREW IN 1/4 TURN MORE.

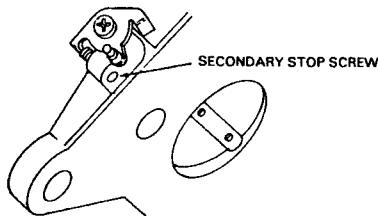

CAUTION: EXCEEDING THIS ADJUSTMENT MAY CAUSE EXCESSIVE SECONDARY PLATE OPENING, AND PREVENT PROPER ADJUSTMENT OF IDLE SPEED AND MIXTURE SETTINGS ON THE PRIMARY SIDE OF THE CARBURETOR.

FIG. 5

CLEARANCE .220"

1. BLOCK PRIMARY THROTTLE ABOUT HALF OPEN.
2. PUSH CHOKE PISTON DOWNWARD AGAINST ADJUSTMENT SCREW. (USING A WIRE WITH A 1/8" BEND AT THE END.)

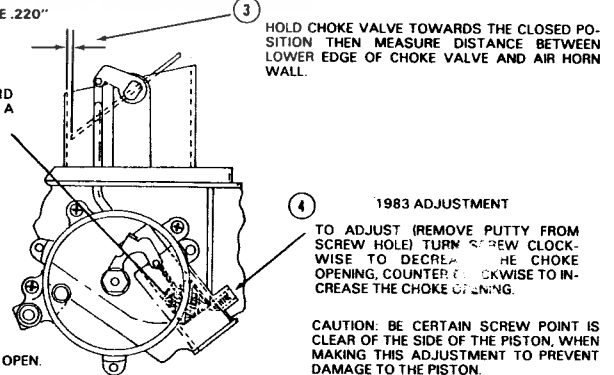

(ALSO SEE FIG. 9)
CHOKE PLATE PULLDOWN ADJUSTMENT

FIG. 6

CLEARANCE .300" MIN.

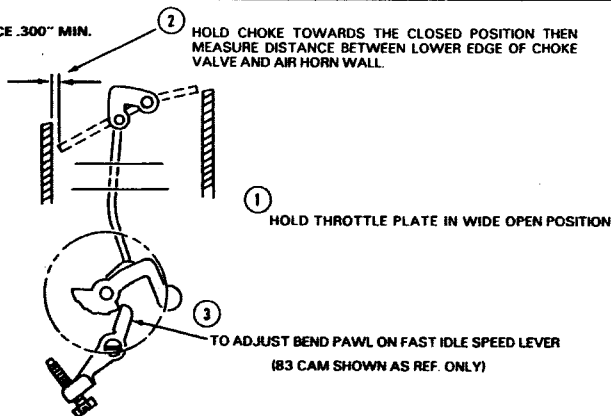

UNLOADER ADJUSTMENT

FIG. 7

ALIGN MARK ON CHOKE COVER WITH PROPER INDEX MARK ON CHOKE HOUSING. SERVICE RETAINING RING WITH NEW BREAK AWAY SCREWS. START ALL 3 SCREWS, THEN TIGHTEN THE TOP 2 SCREWS TO BREAK AWAY BEFORE TIGHTENING THE BOTTOM SCREW.

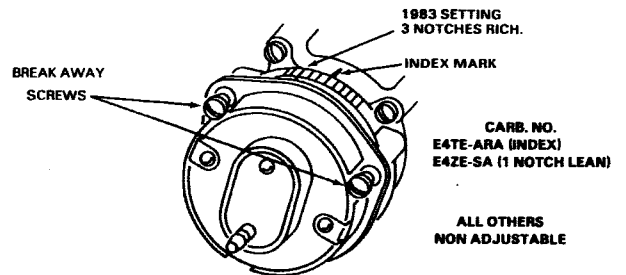

AUTOMATIC CHOKE SETTING

FIG. 8

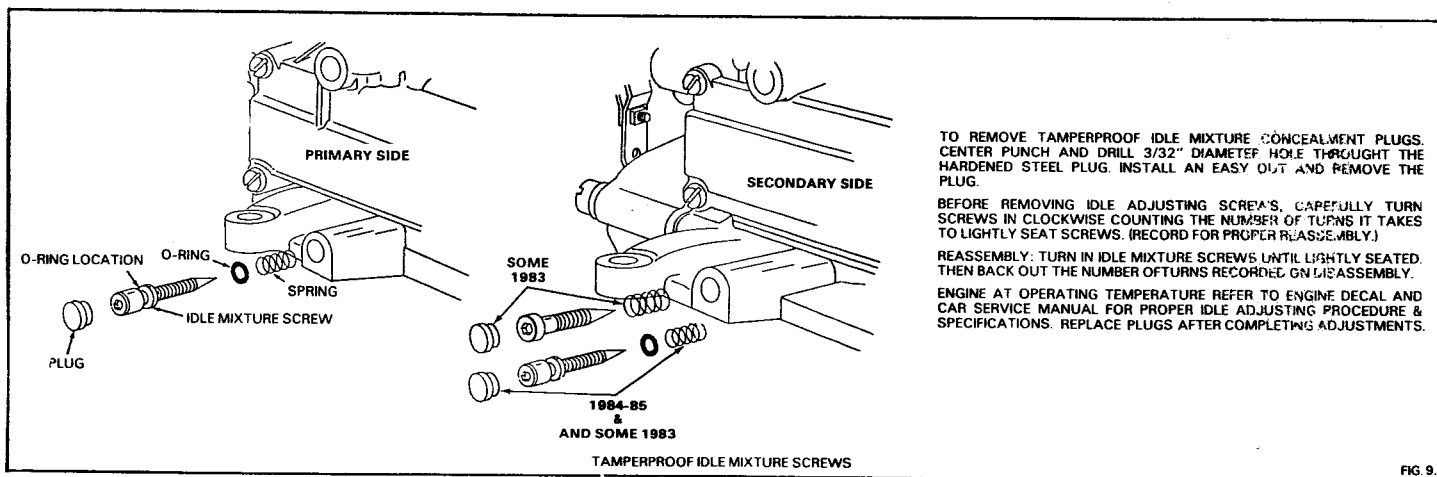

TO REMOVE TAMPERPROOF IDLE MIXTURE CONCEALMENT PLUGS, CENTER PUNCH AND DRILL 3/32" DIAMETER HOLE THROUGH THE HARDENED STEEL PLUG. INSTALL AN EASY OUT AND REMOVE THE PLUG.

BEFORE REMOVING IDLE ADJUSTING SCREWS, CAREFULLY TURN SCREWS IN CLOCKWISE COUNTING THE NUMBER OF TURNS IT TAKES TO LIGHTLY SEAT SCREWS. (RECORD FOR PROPER REASSEMBLY.)

REASSEMBLY: TURN IN IDLE MIXTURE SCREWS UNTIL LIGHTLY SEATED. THEN BACK OUT THE NUMBER OF TURNS RECORDED ON DISASSEMBLY.

ENGINE AT OPERATING TEMPERATURE REFER TO ENGINE DECAL AND CAR SERVICE MANUAL FOR PROPER IDLE ADJUSTING PROCEDURE & SPECIFICATIONS. REPLACE PLUGS AFTER COMPLETING ADJUSTMENTS.

FIG. 9.

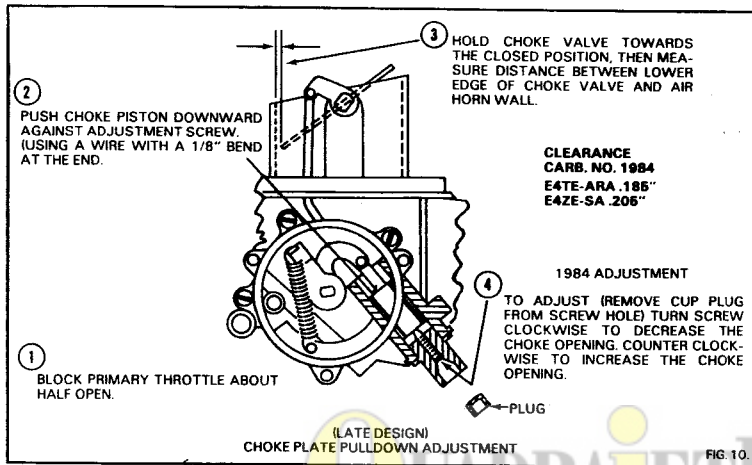

FIG. 10.

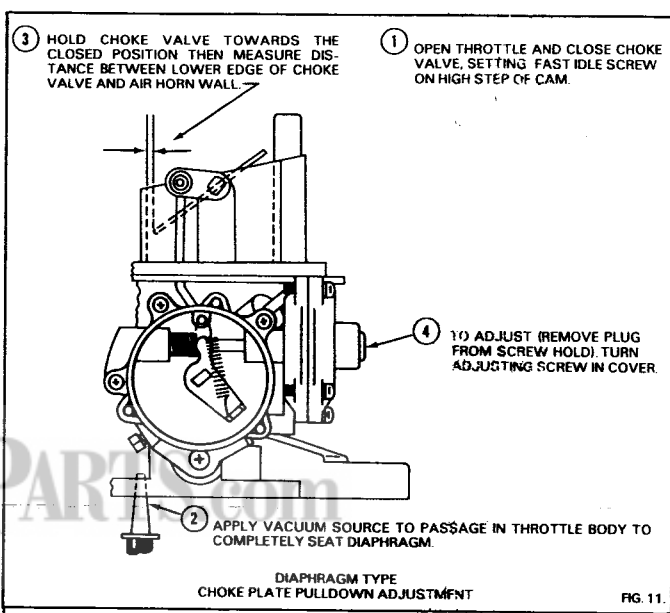
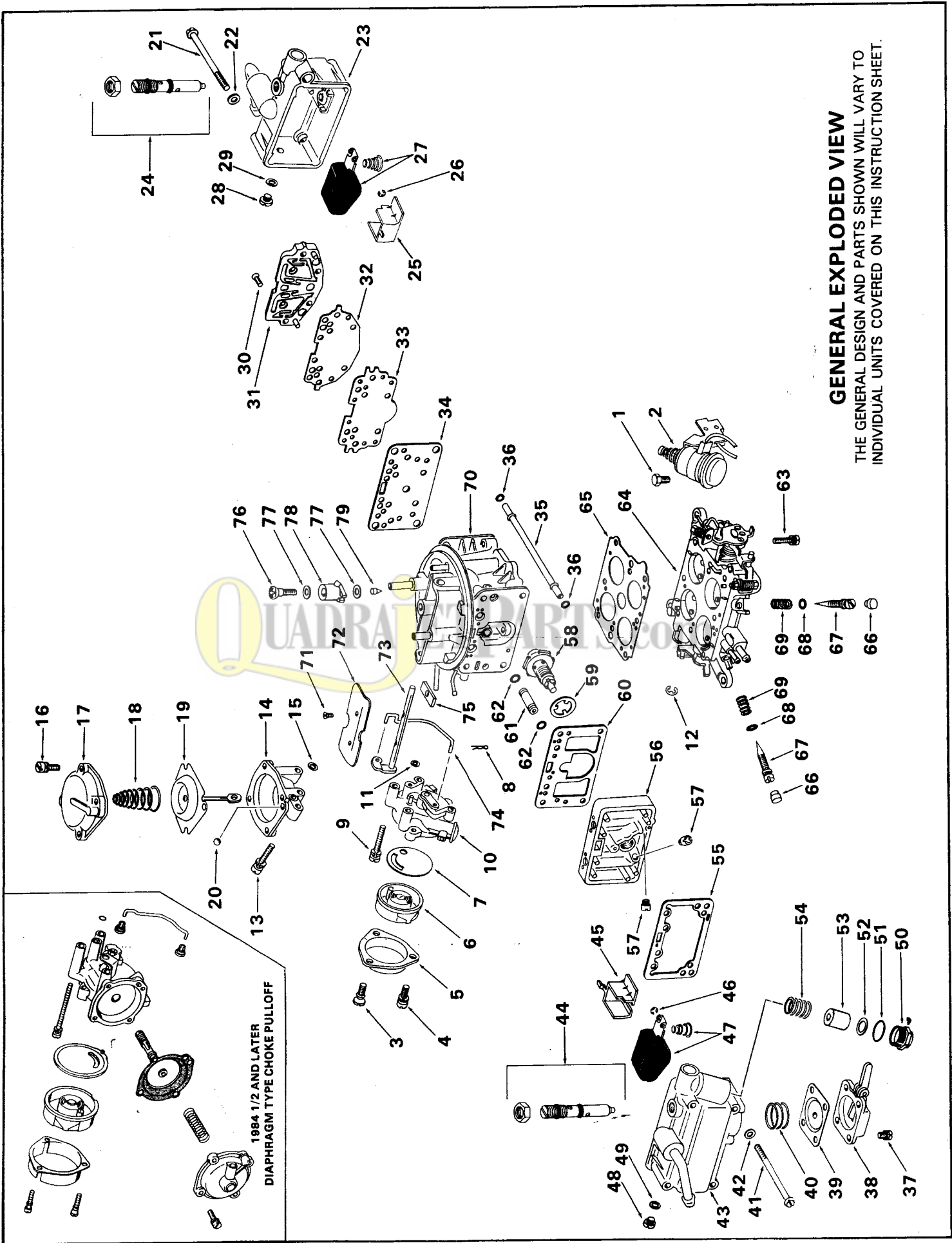

FIG. 11.

CARBURETOR TAB NO.	CLEARANCE
E4ZE-YA	.200"
ESHE-DA-DB-DC-DD-EA-EB-EC-ED	.170"
ESHE-FA	.150"
ESHE-LA-LB-LC-MA-MB-MC	.170"
ESTE-ZA-ZB	.157"
ESTE-ABA	.185"
ESZE-GA	.178"
ESHE-AC	.140"
ESHE-GA-GB	.160"
ESJL-AA-AB-BA	.170"



GENERAL EXPLODED VIEW

THE GENERAL DESIGN AND PARTS SHOWN WILL VARY TO INDIVIDUAL UNITS COVERED ON THIS INSTRUCTION SHEET.