

STROMBERG CARBURETOR

1960-1972 GMC

With Governor

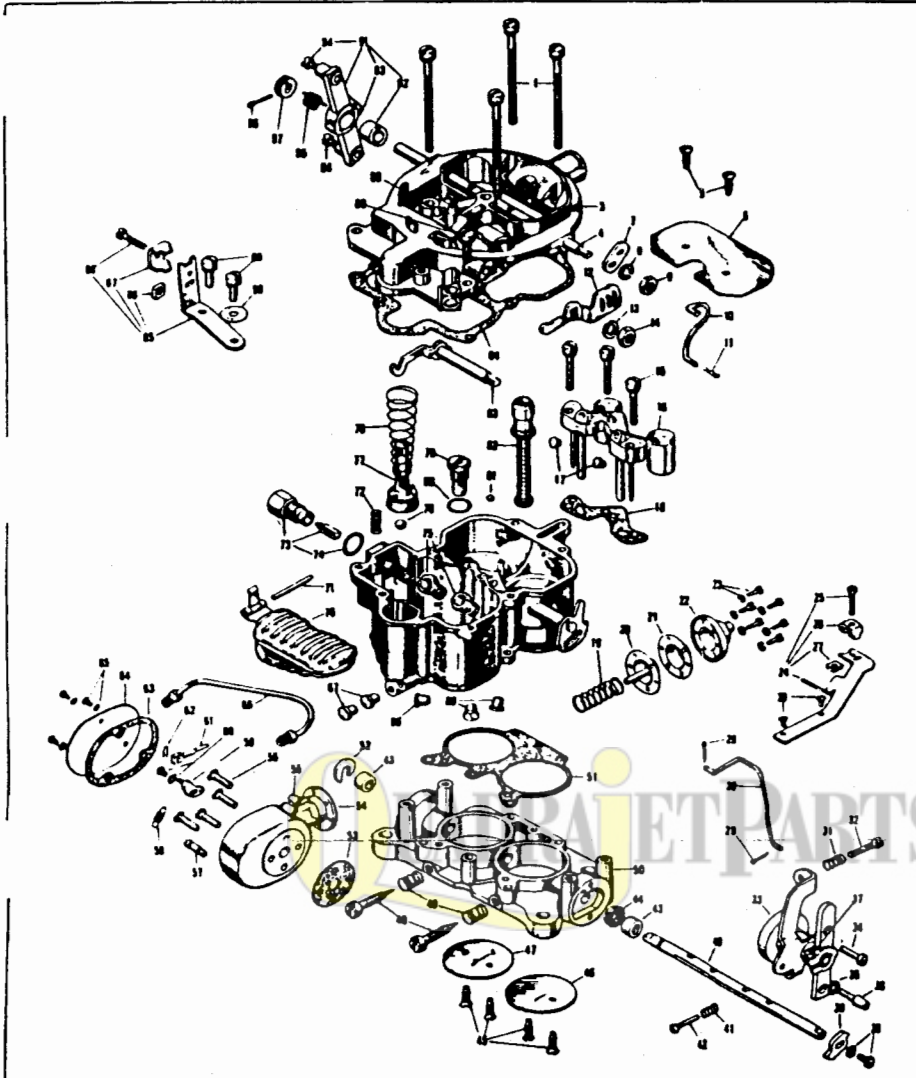

PARTS LIST

KEY NO.	PART NAME
	SCREW & LOCK'W-Air Horn to Th. Body
3	AIR HORN
4	SHAFT & PIN-Choke
5	SCREW-Choke Valve
6	VALVE-Choke
7	LEVER-Fast Idle
8	LOCK'W-Fast Idle
9	NUT-Fast Idle
10	ROD-Fast Idle
11	RETAINER-Fast Idle Rod
12	LEVER-Pump Shaft
13	LOCK'W-Pump Lever Nut
14	NUT-Pump Shaft Lever
15	SCREW & LOCK'W-Venturi
16	VENTURI CLUSTER
17	BLEEDER-Secondary High Speed
18	GASKET-Venturi Cluster
19	SPRING-Governor Diaphragm DIAPHRAGM & STEM-Governor DIAPHRAGM-Governor (Outer) COVER-Governor Diaphragm
20	SCREW & LOCK'W-Diaph. Cover
24	HOLDER-Choke Tube (Lower)
25	SCREW-Choke Tube Clamp
26	CLAMP-Choke Tube

KEY NO.	PART NAME
27	NUT-Choke Tube Holder Clamp
28	SCREW & LOCK'W-Choke Tube Holder
29	COTTER PIN-Pump Rod
30	PUMP ROD
31	SPRING-Fast Idle Screw
32	SCREW-Fast Idle
33	THROTTLE DRIVER
34	SCREW & LOCK'W-Driver Housing
35	LOCK'W-Driver Housing
36	SCREW-Throttle Stop (Driver Hsg.)
37	SCREW-Throttle Lever
38	SCREW & LOCK'W-Throttle Driver
39	THROTTLE DRIVER
40	SHAFT-Throttle
41	SPRING-Slow Idle Screw
42	SCREW-Slow Idle
43	BEARING-Throttle Shaft
44	SEAL-Throttle Shaft
45	SCREW-Throttle Valve
46	VALVE-Throttle (left)
47	VALVE-Throttle (right)
48	VALVE-Idle Needle
49	SPRING-Idle Needle Valve
50	THROTTLE BODY
51	GASKET-Main Body

KEY NO.	PART NAME
52	WASHER-Throttle Shaft
53	GASKET-Governor Housing Flange
54	HOUSING-Governor Throttle
55	CONNECTOR-Governor Air
56	SCREW & LOCK'W-Governor Th.
57	SCREW-Spring Anchor
58	SPRING-Governor
59	LEVER & PIN-Governor Throttle
60	SCREW & LOCK'W-Gov. Th. Lever
61	LINK-Governor Diaphragm
62	RETAINER-Diaphragm Link
63	GASKET-Housing Cover
64	COVER-Governor Housing
65	SCREW & LOCK'W-Housing Cover
66	GOVERNOR AIR LINE
67	PLUG-Drive
68	PLUG-Idle Vent Channel
69	PLUG-Drive
70	FLOAT & LEVER
71	PIN-Float Fulcrum
72	SPRING-Float Fulcrum Pin
73	FLOAT NEEDLE VALVE, S & G
74	GASKET-Float Needle Valve Seat
75	JET-Main Metering
76	BALL-Pump Outlet Check
77	PUMP PISTON
78	SPRING-Pump
79	JET-Power By-Pass
80	GASKET-Power By-Pass
81	BALL-Pump Inlet Check
82	PISTON-Vacuum Power
83	LEVER & SHAFT-Pump
84	GASKET-Air Horn
85	HOLDER-Choke Tube (Upper)
86	NUT-Choke Tube Holder
87	CLAMP-Choke Tube
88	SCREW-Choke Tube Holder
89	SCREW & LOCK'W-Air Horn
90	IDENTIFICATION TAG
91	CHOKE LEVER
92	BUSHING-Choke Lever
93	SCREW-Choke Lever
94	SCREW-Wire Connector
95	SPRING-Choke Torsion
96	COTTER PIN-Choke Spring
97	RETAINER-Choke Spring
*	WASHER-Pump Rod

*Part is not illustrated

BENCH OVERHAUL

1 DISASSEMBLY

Consists of separating the carburetor into three basic groups: air horn, main body, throttle body and the disassembly of each of these groups. Use the exploded illustration as a guide for disassembly and reassembly.

2 CLEANING AND INSPECTION

Thoroughly clean all metal parts in Bendix Metalclene or Speedclene. Blow out all parts and channels with air pressure. Inspect housings for damage, excessive wear, burrs or warpage. **DO NOT CLEAN NON-METALLIC PARTS** in Bendix Metalclene or Speedclene.

BENCH OVERHAUL (continued)

3 REASSEMBLY

When reassembling carburetor use essentially the reverse order from disassembly.

4 ADJUSTMENTS

Adjustments vary with yearly models. Use code number on top of float chamber for identification and refer to specification chart.

5 FLOAT LEVEL SETTING – Steel Type Needle Valve

With fulcrum spring held against fulcrum pin and lip of float held firmly against needle valve, use 1/8" step of float gauge to gauge float level. To reset float, bend float lever next to float (use Tool 73605).

5a FLOAT LEVEL SETTING – Rubber Tip Needle Valve

Hold fulcrum spring against fulcrum pin and *invert* main body with only the weight of the float holding needle valve against its seat. Use 5/32" step of gauge to measure float level of all carburetors with rubber tip needle valves. To reset float, hold float lever away from needle valve when bending float lever to prevent damage to rubber tip of float needle valve.

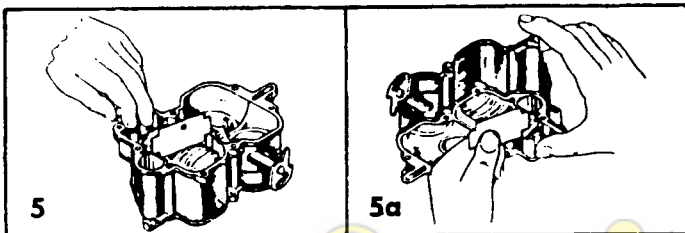

ADJUSTMENTS

Note: The following adjustments 6 thru 8 should be made in numerical sequence. Refer to code for application.

6 FAST IDLE SPEED SETTING (All with FI Cam)

With fast idle rod at center of slot in fast idle cam, adjust fast idle stop screw to the point of initial contact with the fast idle cam when throttle is in fully closed position. Then turn fast idle stop screw "IN" 7-1/2 turns on all units except Code Nos. 23-187, 23-188, 23-217, 23-223, 23-232, 23-233, 23-245, 23-246, 23-249 & 23-252 which require 12-1/2 turns and Code Nos. 23-189, 23-197A, 23-198A & 23-228 which require 10-1/4 turns. Use a 15/64" drill to gauge choke valve opening on 23-187, 23-188, 23-197A & 23-198A with fast idle screw on 2nd stop of fast idle cam. Code No. 23-251 requires 12-1/4 turns.

7 ACCELERATING PUMP TRAVEL

Measure pump travel from closed to open throttle. This travel should be as specified for each carburetor as listed in the table below. When pump travel is not as specified, bend pump rod at point indicated.

Code No.	Slot	Pump Travel
23-125C, 23-128A, 23-144, 23-145, 23-171, 23-172	Middle	9/32" - 5/16"
23-131, 23-146A, 23-148	Inner	3/16"
23-147, 23-251	Outer	3/16"
23-184, 23-185, 23-187, 23-188, 23-189, 23-191, 23-197A, 23-198A, 23-199A, 23-217, 23-218, 23-223, 23-228, 23-229, 23-232, 23-233, 23-234, 23-245, 23-246, 23-247, 23-249, 23-250, 23-252	Outer	9/32" - 5/16"

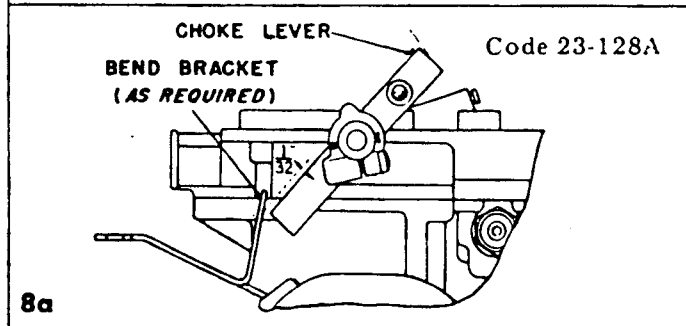
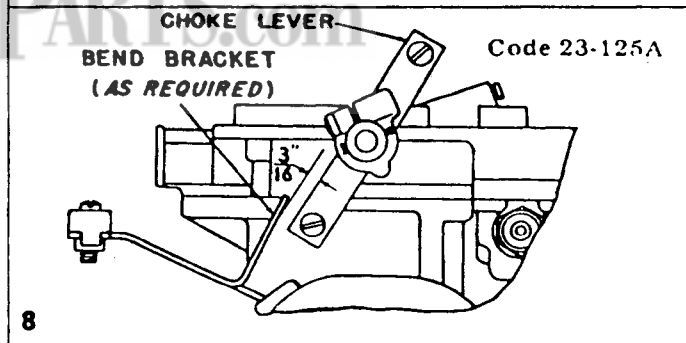
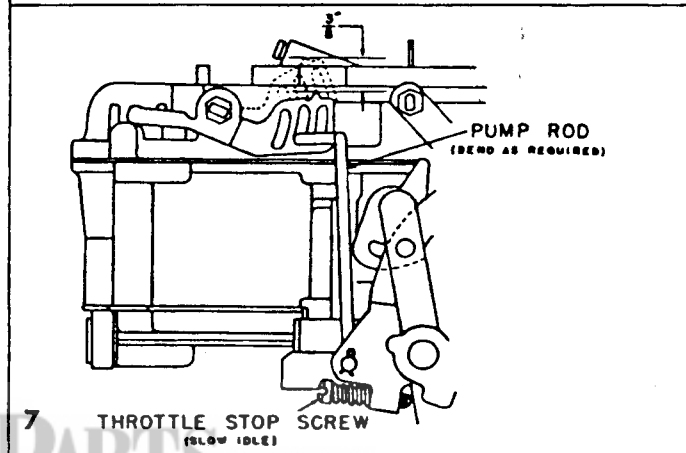
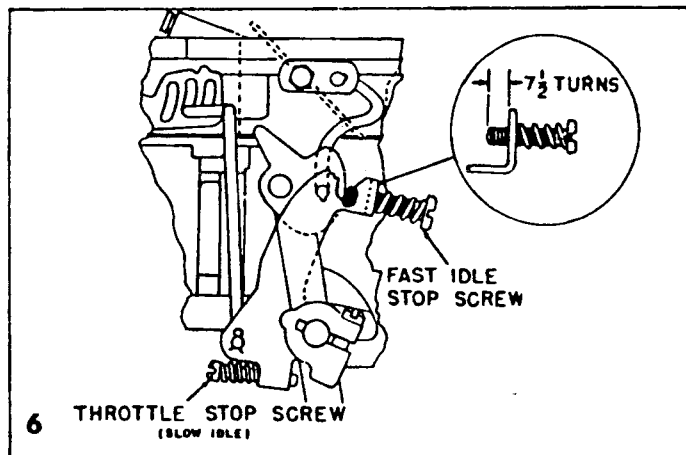

8 CHOKE LEVER OVER-TRAVEL SETTING

Adjust for specified lever overtravel from closed choke to stop bracket. When overtravel is not as specified, bend bracket as required.