

# INSTRUCTION SHEET

## STROMBERG CARBURETOR—MODEL-WW

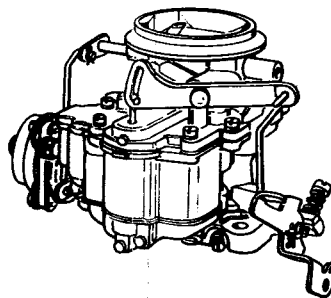

### I. DISASSEMBLY.

Using the exploded views on reverse side as a guide, disassemble the unit far enough to permit thorough cleaning and inspection of parts.

### II. CLEANING.

After disassembly, soak metal parts long enough to soften and remove all foreign material. Use a regular carburetor cleaning solvent; lacquer thinner; or denatured alcohol. Use a small brush to aid cleaning, if necessary. Make certain the throttle body is free of all hard carbon deposits. Blow out all passages in castings with compressed air, and check carefully to insure thorough cleaning of obscure areas. Do not soak rubber or leather parts in solvent.

### III. REASSEMBLY.

- Lubricate pump plunger cup with engine oil and also slightly flare the plunger up with finger tips, to provide free action and a better seal. Soak in oil for several minutes if time permits.
- Reassemble, using essentially the reverse order of disassembly.
- Check operation of choke valve to determine that thermostat coil contacts the linkage.

### IV. FLOAT SETTING ADJUSTMENT. (See figure 1.)

Apply pressure with forefinger against float lip to hold inlet needle closed and float pin in the bottom of its groove in main body. With float held in this position, measure the distance from top edge of body to top surface of float at (A, figure 1) with gage supplied in kit. Bend float lip to adjust. (See Adjustment Table, page 4.)

### V. PUMP ROD ADJUSTMENT.

a. See Figure 2 and Adjustment Data Table. With throttle valves fully closed (throttle stop screw backed out) the distance between top of accelerating pump link and top of air horn (B) should be as listed in the table when measured with a scale. To adjust, bend pump rod at point indicated.

b. See Figure 3 and Adjustment Data Table. Hold carburetor in vertical position and operate pump to permit check ball to take its normal position on seat. With choke valve held open and pump rod in center hole of throttle lever, measure travel (C) of accelerating pump as throttle valves are moved from fully closed to wide open position. When pump travel is not as specified in the table, bend pump rod as required at angle.

c. See Figure 4 and Adjustment Data Table. Place Pump Vent Clip in center notch on pump stem. Pump rod in center hole of throttle lever, back off idle stop screw choke valve wide open and throttle valves tightly closed. Measure between bowl vent and vent seat. Bend rod to adjust.

### VI. UNLOADER ADJUSTMENT. (See Adjustment Data Table.)

a. Figure 5. Hold choke valve closed lightly, then open throttle to wide-open position. The distance "D" between choke valve and air horn wall should be as listed in table. To adjust, bend ear on throttle lever as shown.

b. Figure 6. Hold choke valve closed lightly, then open throttle to wide-open position. The distance "E" between choke valve and air horn wall should be as listed in table. Make sure all parts are held so that slack will be removed from linkage. To adjust, bend cam contact lever ear as shown.

### VII. AUTOMATIC CHOKE SETTING.

Set mark on stat cover to align with center mark on choke housing. (Allowable variations 2 notches either way from index.)

### VIII. DASHPOT ADJUSTMENT. (See figure 7.)

Hold throttle closed and push dashpot plunger all the way in. Adjust plunger screw to provide a clearance of 1/32-inch to 1/16-inch at (F, figure 7).

### IX. IDLE ADJUSTMENT. (See figure 8.)

Install carburetor on engine and run the engine until warm. Adjust the throttle stop screw (1) to produce a speed of approximately 450-500 rpm. Rotate the idle needles (2) until a smooth idle is obtained. Readjust (1 and 2) alternately to produce a smooth idle.

## ADJUSTMENTS

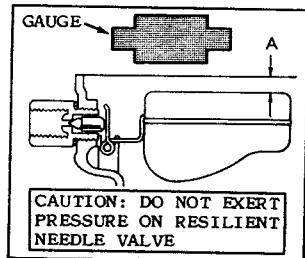

FLOAT LEVEL Fig.1

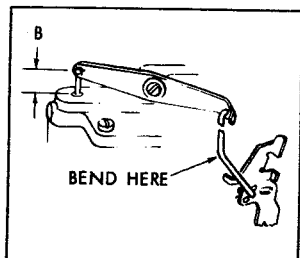

PUMP ADJ. Fig.2

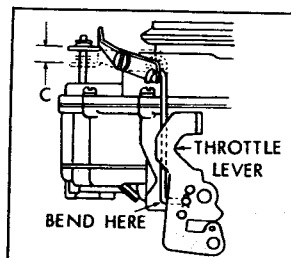

PUMP ADJ. Fig.3

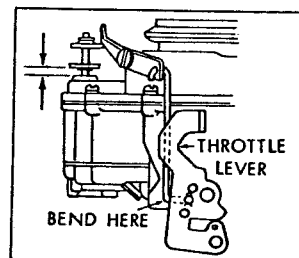

PUMP ADJ. Fig.4

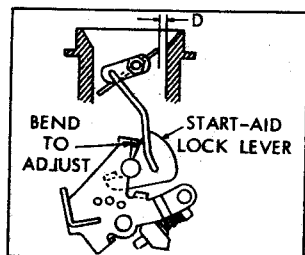

UNLOADER ADJ. Fig.5

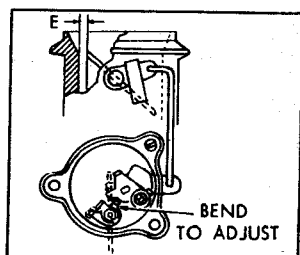

UNLOADER ADJ. Fig.6

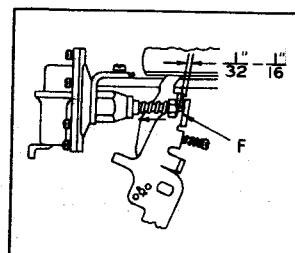

DASHPOT ADJ. Fig.7

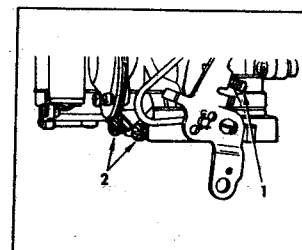

IDLE ADJ. Fig.8

# EARLY MODELS

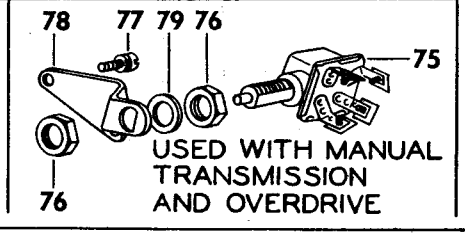
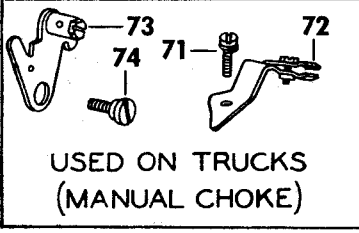
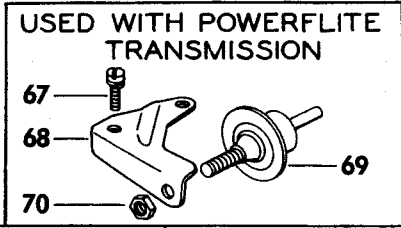
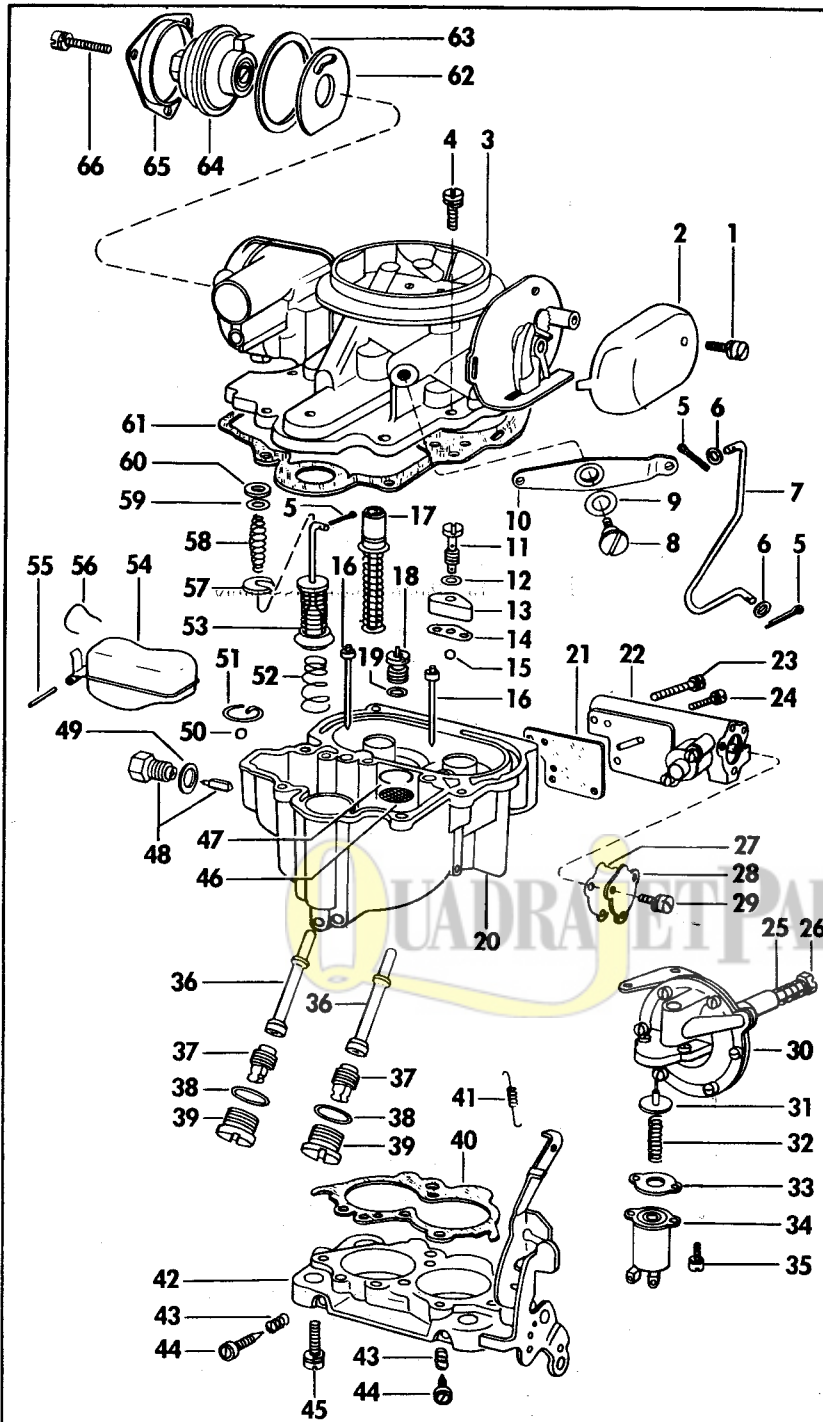

Ref. No.	NOMENCLATURE
1	Screw and Washer Assembly
2	Cover - Fast idle
3	Air Horn Assembly
4	Screw and Washer Assembly
5	Pin - Cotter
6	Washer - Pump rod
7	Rod - Pump
8	Screw - Pump lever fulcrum
9	Washer - Pump lever fulcrum screw
10	Lever - Pump
11	Screw - Pump discharge nozzle
12	Gasket - Pump discharge nozzle screw
13	Nozzle - Pump discharge
14	Gasket - Pump discharge nozzle
15	Ball - Pump outlet check
16	Tube - Idle
17	Piston Assembly - Vacuum power
18	Jet - Power by-pass
19	Gasket - Power by-pass jet
20	Main Body
21	Gasket - Kickdown switch housing
22	Housing - Kickdown switch (Gyro-Matic)
23	Screw and Washer Assembly
24	Screw and Washer Assembly
25	Spring - Dashpot plunger screw
26	Screw - Dashpot plunger
27	Gasket - Piston retainer plate
28	Plate - Piston retainer
29	Screw and Washer Assembly
30	Dashpot Assembly (Gyro-Matic)
31	Plunger - Solenoid
32	Spring - Plunger
33	Gasket - Solenoid housing
34	Solenoid Assembly - Dashpot
35	Screw and Washer Assembly
36	Jet (Nozzle) - Main discharge
37	Jet - Main metering
38	Gasket - Metering jet plug
39	Plug - Main discharge jet
40	Gasket - Main body
41	Spring - Fast idle loose lever
42	Throttle Body
43	Spring - Idle needle valve
44	Valve - Idle needle
45	Screw and Washer Assembly
46	Screen - Pump
47	Retainer - Pump screen
48	Needle and Seat Assembly
49	Gasket - Needle seat
50	Ball - Pump inlet check
51	Retainer - Check ball
52	Spring - Pump
53	Piston Assembly - Pump
54	Float Assembly
55	Pin - Float
56	Spring - Float pin
57	Washer - Spring cup
58	Spring - Packing retainer
59	Washer - Pump link seal
60	Packing - Pump
61	Gasket - Air horn
62	Baffle - Choke housing
63	Gasket - Thermostat cover
64	Thermostat and Cover Assembly
65	Retainer - Thermostat cover
66	Screw and Washer Assembly

The following parts are not used on all models

67	Screw and Washer Assembly
68	Bracket - Dashpot
69	Dashpot Assembly (Power Flite)
70	Nut - Dashpot
71	Screw and Washer Assembly
72	Holder - Choke tube
73	Lever - Choke
74	Screw - Choke lever
75	Switch - Overdrive kickdown
76	Nut - Kickdown switch adjusting
77	Screw and Washer Assembly
78	Bracket - Kickdown switch
79	Washer - Spacer

# LATE MODELS

## GENERAL EXPLODED VIEW

THE GENERAL DESIGN AND PARTS SHOWN WILL VARY TO INDIVIDUAL UNITS COVERED ON THIS INSTRUCTION SHEET

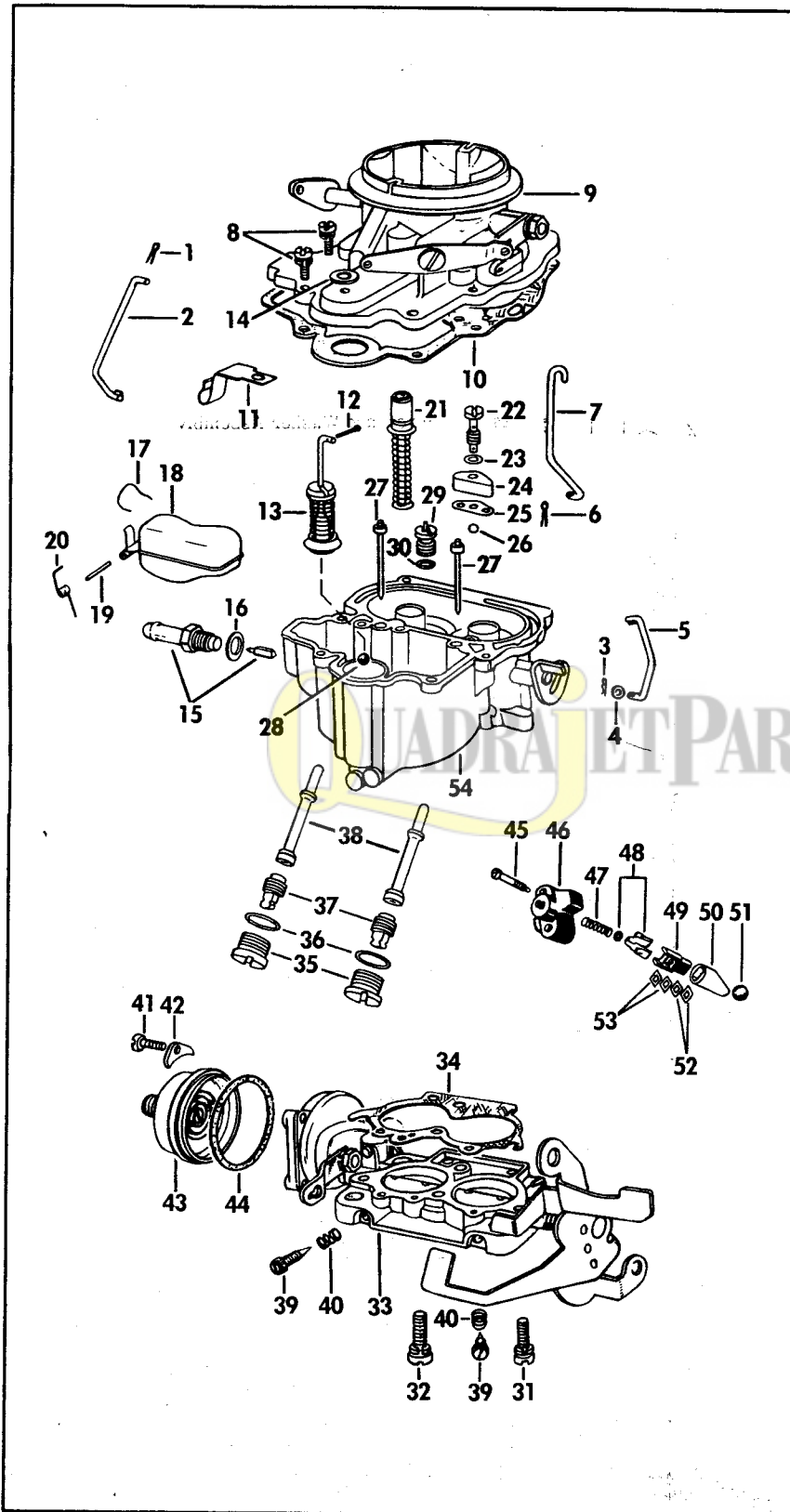

### REF. NO. NOMENCLATURE

- 1 Cotter pin
- 2 Choke connector rod
- 3 Pin spring
- 4 Washer
- 5 Unloader link
- 6 Cotter pin
- 7 Pump rod
- 8 Screw and washer assembly
- 9 Air horn assembly
- 10 Air horn gasket
- 11 Cable clip
- 12 Cotter pin
- 13 Pump plunger assembly
- 14 Pump plunger washer
- 15 Needle and seat assembly
- 16 Needle seat gasket
- 17 Float pin spring
- 18 Float assembly
- 19 Float pin
- 20 Float spring
- 21 Vacuum power piston assembly
- 22 Pump discharge nozzle screw
- 23 Pump discharge nozzle screw gasket
- 24 Pump discharge nozzle
- 25 Pump discharge nozzle gasket
- 26 Pump outlet check ball
- 27 Idle tube
- 28 Pump inlet check ball
- 29 Power by-pass jet
- 30 Power by-pass jet gasket
- 31 Screw and washer assembly (short)
- 32 Screw and washer assembly (long)
- 33 Throttle body assembly
- 34 Main body gasket
- 35 Main discharge jet plug
- 36 Main jet plug gasket
- 37 Main metering jet
- 38 Main discharge nozzle
- 39 Idle needle valve
- 40 Idle needle valve spring
- 41 Screw (self-tapping)
- 42 Thermostat cover retainer
- 43 Thermostat and cover assembly
- 44 Thermostat cover gasket
- 45 Starter switch cover screw
- 46 Starter switch cover
- 47 Switch return spring
- 48 Switch contact spring
- 49 Switch guide block
- 50 Switch plunger
- 51 Switch ball
- 52 Switch adjustment washer (thick)
- 53 Switch adjustment washer (thin)
- 54 Main body

# ADJUSTMENT DATA TABLE

Year	Make	Float Level	PUMP ADJUSTMENT				Unloader
			Fig.	Pump Stem Groove	Throttle Lever Hole or Slot	Dimen.	
1955-56	Buick	3/16"	2			31/32"	9/64"
1956	Buick - 40 S/T	3/16"	3			3/8"	9/64"
1957	Buick	7/32"	3			3/8"	9/64"
1958	Buick	3/16"	3			3/8"	9/64"
1959	Buick	3/16"	2			7/8"	9/64"
1960-61	Buick	3/16"	2			7/8"	9/64"
1955	Chrysler-Windsor	3/16"	3			1/4"	3/16"
1956-57	Chrysler-Windsor	7/32"	3			1/4"	3/16"
1955-56	DeSoto (except Fire Flight)	3/16"	3			1/4"	3/16"
1957	DeSoto - Firesweep	7/32"	3			5/16"	1/4"
1957	DeSoto - Firedome	7/32"	3			1/4"	3/16"
1955-56	Dodge 6 cyl.	3/16"	3			1/4"	3/16"
1957-58	Dodge 6 cyl.	7/32"	3			1/4"	3/16"
1953-54	Dodge 8 cyl.	3/16"	2			3/4"	3/16"
1955	Dodge 8 cyl.	3/16"	3			1/4"	3/16"
1956	Dodge 8 cyl.	7/32"	3			1/4"	3/16"
1957-58	Dodge 8 cyl.	7/32"	3			5/16"	1/4"
1959	Dodge 8 cyl.	7/32"	3			9/32"	3/16"
1960-65	Dodge and Dart 8 cyl.	7/32"	4	Middle	Middle	3/32"	9/32"
1966-67	Dodge 318" Eng. & w/C.A.P.	7/32"	4	Middle	Middle	3/32"	5/16"
1967	Dodge 318" Eng. A/T & C.A.P.	7/32"	4	Top	Inner Slot	5/64"	5/16"
1955-56	Dodge Truck 8 cyl.	3/16"	3	-	-	1/4"	3/16"
1957-62	Dodge Truck 8 cyl.	7/32"	3	-	-	5/16"	1/4"
1960	Dodge Truck, 3-191, 192	7/32"	4	Middle	Middle	3/32"	1/4"
1961-64	Dodge Trk. 313" & 318" Eng.	7/32"	4	Middle	Middle	3/32"	1/4"
1963-64	Dodge Trk. 3-226	7/32"	3	-	-	5/16"	-
1962-64	Dodge Trk. 361" Eng.	7/32"	3	-	-	5/16"	-
1965-66	Dodge Trk. 318" Eng. S/T C.A.P.	7/32"	3	-	Top	5/16"	-
1967	Dodge Trk. 318" Eng. C.A.P.	7/32"	4	Middle	Middle	7/64"	5/16"
1967	Dodge Trk. 318" Eng. C.A.P. 3-279	7/32"	4	Middle	Inner Slot	1/8"	-
1967-68	Dodge Trk. 318" Eng.	7/32"	4	Middle	Inner Slot	7/64"	-
1967-68	Dodge Trk. 318" Eng. A/T	7/32"	4	Middle	Middle	7/64"	5/16" - 67 15/64" - 68
1968	Dodge Trk. 318" Eng. S/T C.A.P.	7/32"	4	Middle	Inner Slot	3/32"	-
1968	Dodge Trk. 318" Eng. A/T C.A.P.	7/32"	4	Middle	Middle	5/64"	5/16"
1956	G.M.C. Truck 6 cyl.	3/16"	3			3/8"	3/16"
1957-59	G.M.C. Truck 6 cyl.	3/16"	2			1"	-
1960-63	G.M.C. Truck 6 cyl.	3/16"	2			15/16"	-
1965-66	G.M.C. Truck 6 cyl. 305"E 305C Eng.	3/16"	2			15/32"	-
1955-56	G.M.C. Truck 8 cyl.	3/16"	3			3/8"	3/16"
1957-59	G.M.C. Truck 8 cyl.	3/16"	2			15/32"	-
1956-59	Plymouth 8 cyl.	7/32"	3			5/16"	1/4"
1960-65	Plymouth & Valiant 8 cyl.	7/32"	4			3/32"	9/32"
1966-67	Plymouth 318" Eng. & w/C.A.P.	7/32"	4	Middle	Middle	3/32"	5/16"
1967	Plymouth 318" Eng. A/T & C.A.P.	7/32"	4	Top	Inner Slot	5/64"	5/16"
1953-57	Studebaker Pass.	3/16"	3			5/16"	1/4"
1957-58	Studebaker 6-121C, 122A	7/32"	3			9/32"	7/32"
1959-62	Studebaker Pass.	3/16"	2			5/8"	3/16"
1963	Studebaker Pass. V8	3/16"	2			13/16"	3/16"
1964	Studebaker Pass. V8	3/16"	-			-	3/16"
1955-58	Studebaker Truck	3/16"	3			5/16"	1/4"
1959-62	Studebaker Truck	3/16"	2			5/8"	3/16"
1963	Studebaker Truck	3/16"	2			13/16"	3/16"

W/C.A.P. = WITH CLEAN AIR PACKAGE